



D.O.O. METALNA IDUSTRIJA VRANJE
Radnička br. 1

PELLET STOVE

TINA
UNA



Technical manual for user, installation and maintenance
ENG_v.1.0

PELET STOVE FOR HEATING „TINA / UNA”

Heating devices (in this manual they are called “stoves”) by Alfa Plam (in this manual titled Alfa Plam) are assembled and tested in accordance with the safety and applicable measures, and regulations of the European Community.

This manual is intended for users of the stoves, contractors who install the stoves, operators and workers for stove maintenance that is shown on the front page of the manual.

If you do not understand something in this manual, please contact our professional services or an authorized service center. In doing so, always specify the number of the chapter where there is some ambiguity.

Printing, translation and reproduction, even in part, of this manual is subject to licensing by Alfa Plam, which means that Alfa Plam must approve these actions. Technical information, figures, and specifications in this manual must not be given to a third party.

WARNING:

IMPORTANT: Connecting the appliance to the electrical installation must be carried out by qualified and authorized persons in accordance with applicable regulations.

This appliance is not intended for use by persons (including children) with reduced physical, motor, and mental capabilities, or to persons with a limited knowledge and experience in the absence of the person responsible for their safety or care.

Children cannot be allowed to play with this appliance.

DOUBLE COMBUSTION SYSTEM

The flame obtained by proper combustion of the pellet in the stove emits the same amount of carbon dioxide (CO₂), which would be freed as a result of the natural decay of wood.

The amount of carbon dioxide (CO₂) obtained through combustion or decomposition of plant mass corresponds to the amount of carbon dioxide (CO₂) which the plant mass is able to obtain from the environment and to transform it into air and carbon of the plants during its entire lifetime.

The use of non-renewable fossil fuels (coal, oil, gas), contrary to what happens with the wood, releases into the atmosphere huge amounts of carbon dioxide (CO₂), that have been gathering up for millions of years, creating a greenhouse effect. The use of wood as fuel is therefore perfectly balanced with the environment, because the wood as a renewable fuel is in ecological harmony with nature.

Using the principle of clean combustion, we fully achieve these objectives, and so Alfa Plam has directed its development and all activities towards fulfilling this goal.

What do we consider clean combustion and how does it work?

Controlling and adjusting the primary air and injecting the secondary air causes secondary combustion, or the so-called post-combustion, which provides a secondary flame that is by its nature lighter and stronger than the primary flame. The addition of a new oxygen (inserted through the air) allows further combustion of gases that are not completely burned. This significantly increases the thermal efficiency and reduces harmful emissions of carbon monoxide (CO), because the incomplete combustion is minimized. These are the basic characteristics of these stoves and other products of Alfa Plam.

CAUTION

- The chimney, to which the stove is connected must meet the requirements provided in the user manual.
- When connecting the appliance to the chimney, never use flexible hoses instead of flue pipes.
- Regular maintenance and care, such as cleaning the stove, the flue pipes and the nozzles (of the pipes), are important to ensure safety, and especially for the sake of economy and in order to maintain the value of the stove.
- Unauthorized modification of the device is prohibited and therefore any unauthorized modification shall render the warranty null and void.

DESCRIPTION

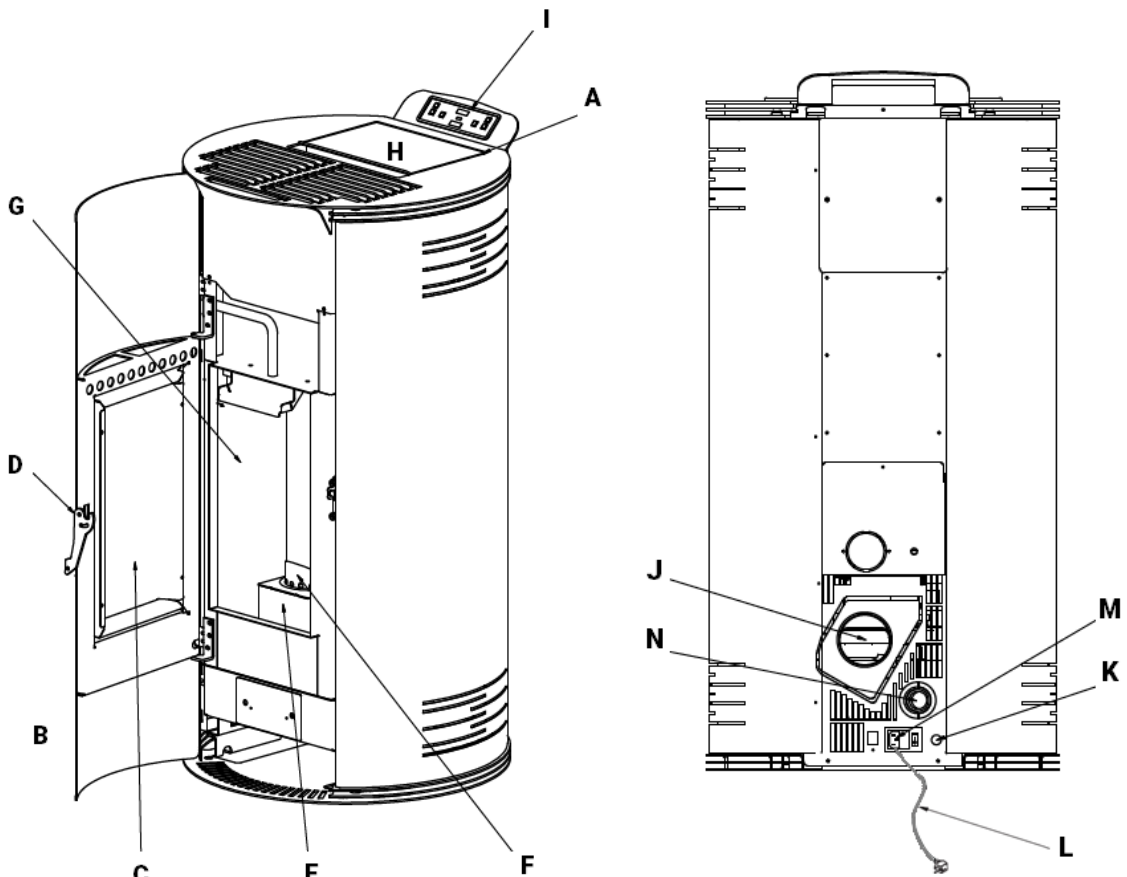

Figure 1

	ENGLISH
A	Pellet lid
B	Firebox door
C	Glass panel
D	Handle
E	Optional Ash drawer
F	Burning pot
G	Fireplace
H	Fuel hopper
I	Display
J	Flue
K	Probe
L	Power cord
M	Main switch
N	Air intake

TECHNICAL FEATURES

No.	Parameter	Unit	Explanation	Tina / Una
1	P_{nom}	kW	the nominal heat output or a range of outputs (dependent on fuel types), rounded to the nearest one decimal place	7,2
2	P_{SHnom}	kW	the nominal space heat output or a range of outputs (dependent on fuel types), rounded to the nearest one decimal place	7,2
3	P_{Wnom}	kW	the nominal water output (if an integral boiler is fitted) or a range of outputs (dependent on fuel types), rounded to the nearest one decimal place	--
4	P_{part}	kW	the part load heat output or a range of outputs (dependent on fuel types) if specified, rounded to the nearest one decimal place	3,0
5	P_{SHpart}	kW	the part load space heat output or a range of outputs (dependent on fuel types) if specified, rounded to the nearest one decimal place	3,0
6	P_{Wpart}	kW	the part load water output (if an integral boiler is fitted) or a range of outputs (dependent on fuel types) if specified, rounded to the nearest one decimal place	--
7	P_{slow}	kW	the heat output at slow combustion or a range of outputs (dependent on fuel types) if specified, rounded to the nearest one decimal place	--
8	P_{SHslow}	kW	the space heat output at slow combustion or a range of outputs (dependent on fuel types) if specified, rounded to the nearest one decimal place	--
9	P_{Wslow}	kW	the water heat output at slow combustion (if an integral boiler is fitted) or a range of outputs (dependent on fuel types) if specified, rounded to the nearest one decimal place	--
10	$P_{acc in}$	kW	accumulator heat input, in kW or W for Kachelofen inset appliances only, rounded to the nearest one decimal place	--
11	$T_{acc in}$	°C	temperature at the separate heat exchanger inlet, for Kachelofen inset appliances only, rounded to the nearest integer	--
12	ζ_{acc}	Pa	the flow resistance of the separate heat exchanger as used in the test, for Kachelofen inset appliances only, rounded to the nearest integer	--
13	η_{nom}	%	the appliance efficiency at nominal heat output, rounded to the nearest integer	92,8
14	η_{part}	%	the appliance efficiency at part load heat output, rounded to the nearest integer	95,2
15	η_S	%	the appliance seasonal space heating efficiency at nominal heat output, rounded to the nearest integer	88,9
16	EEI	-	the energy efficiency index, rounded to the nearest integer	131
17	CO_{nom} (13 % O ₂)	mg/Nm ³	CO emission at 13 % oxygen content at nominal heat output, rounded to the nearest integer r	78
18	CO_{part} (13 % O ₂)	mg/Nm ³	CO emission at 13 % oxygen content at part load heat output if specified, rounded to the nearest integer	66
19	CO_{slow} (13 % O ₂)	mg/Nm ³	CO emission at 13 % oxygen content at heat output at slow combustion if specified, rounded to the nearest integer	--
20	NO_{xnom} (13 % O ₂)	mg/Nm ³	NOx emission at 13 % oxygen content at nominal heat output, rounded to the nearest integer	124
21	NO_{xpart} (13 % O ₂)	mg/Nm ³	NOx emission at 13 % oxygen content at part load heat output if specified, rounded to the nearest integer	132
22	NO_{xslow} (13 % O ₂)	mg/Nm ³	NOx emission at 13 % oxygen content at heat output at slow combustion if specified, rounded to the nearest integer	--
23	OGC_{nom} (13 % O ₂)	mg/Nm ³	hydrocarbon emission at 13 % oxygen content at nominal heat output, rounded to the nearest integer	11
24	OGC_{part} (13 % O ₂)	mg/Nm ³	hydrocarbon emission at 13 % oxygen content at part load heat output if specified, rounded to the nearest integer	7
25	OGC_{slow} (13 % O ₂)	mg/Nm ³	hydrocarbon emission at 13 % oxygen content at heat output at slow combustion if specified, rounded to the nearest integer	--
26	PM_{nom} (13 % O ₂)	mg/Nm ³	particulate matter emission at 13 % oxygen content at nominal heat output, rounded to the nearest integer	15
27	PM_{part}	mg/Nm ³	particulate matter emission at 13 % oxygen content at part load heat	18

	(13 % O ₂)		output if specified, rounded to the nearest integer	
28	PM_{slow} (13 % O ₂)	mg/Nm ³	particulate matter emission at 13 % oxygen content at heat output at slow combustion if specified, rounded to the nearest integer	--
29	P_{nom}	Pa	minimum flue draught at nominal heat output, rounded to the nearest integer	12
30	P_{part}	Pa	minimum flue draught at part load heat output if specified, rounded to the nearest integer	10
31	P_{slow}	Pa	minimum flue draught at heat output at slow combustion if specified, rounded to the nearest integer	--
32	P_W	kPa (bar)	the permissible maximum water operating pressure, if applicable, to be given with 1 decimal	--
33	d_R	mm	the minimum distances from the rear to combustible material, rounded to the nearest integer	200
34	d_S	mm	the minimum distances from the sides to combustible material, rounded to the nearest integer	200
35	d_C	mm	the minimum distances from the top to combustible material in the ceiling, rounded to the nearest integer	750
36	d_p	mm	the minimum distances from the front to combustible material, rounded to the nearest integer	700
37	d_F	mm	the minimum distances from the front to combustible material in bottom front radiation area, rounded to the nearest integer	1500
38	d_L	mm	the minimum distances from the front to combustible material in side front radiation area, rounded to the nearest integer	1500
39	d_B	mm	the minimum distances below the bottom (not regarding feet) to combustible material, rounded to the nearest integer	0
40	d_{non}	mm	the minimum distances to non-combustible walls, rounded to the nearest integer	--
41	s	mm	Protective insulation according to manufacture r's instructions	--
42	el_{SB}	kW	the consumption of electrical auxiliary energy at standby, to be given with 3 decimals	0,004
43	el_{max}	kW	the consumption of electrical auxiliary energy at nominal heat output, to be given with 3 decimals	0,082
44	el_{min}	kW	the consumption of electrical auxiliary energy at part load heat output, to be given with 3 decimals	0,043
45	E, f	V, Hz	Power supply voltage, frequency, rounded to the nearest integer	230V, 50 Hz
46	W_{max}	W	Maximum electric power input, rounded to the nearest integer	--
47	T_{snom}	°C	the flue gas outlet temperature at nominal heat output, rounded to the nearest integer	140
48	T_{spart}	°C	the flue gas outlet temperature at part load heat output, rounded to the nearest integer (to be given for pellet operation only)	79
49	T_{class}	-	Chimney designation according to the appropriate chimney standard	T 200 G
50	$\phi_{g, nom}$	g/s	the flue gas mass flow at nominal heat output, rounded to the nearest one decimal place	5,0
51	$\phi_{g, part}$	g/s	the flue gas mass flow at part load heat output rounded to the nearest one decimal place (to be given for pellet operation only)	2,9
52	V_h	m ³ /h	The standing air loss, if specified, rounded to the nearest one decimal place	--
53	CON or INT	-	whether the appliance is capable of continuous operation (CON), whether the appliance is capable of intermittent operation (INT)	INT
54	d_{out}	mm	the diameter of the flue gas outlet, rounded to the nearest integer	80
55	L, H, W	mm	the overall dimensions of the appliance (length, height, width), rounded to the nearest integer ^a	567 x 1096 x 545
56	m	kg	Mass of the appliance, rounded to the nearest integer	87
57	m_{chim}	kg	the maximum load of a chimney the appliance may carry, to be rounded to the nearest integer	0
58		-	meaning "read and follow the user operating instructions"	

Table 1

DIMENSIONS

Dimensioni (mm) - Dimensions (mm) - Abmessungen

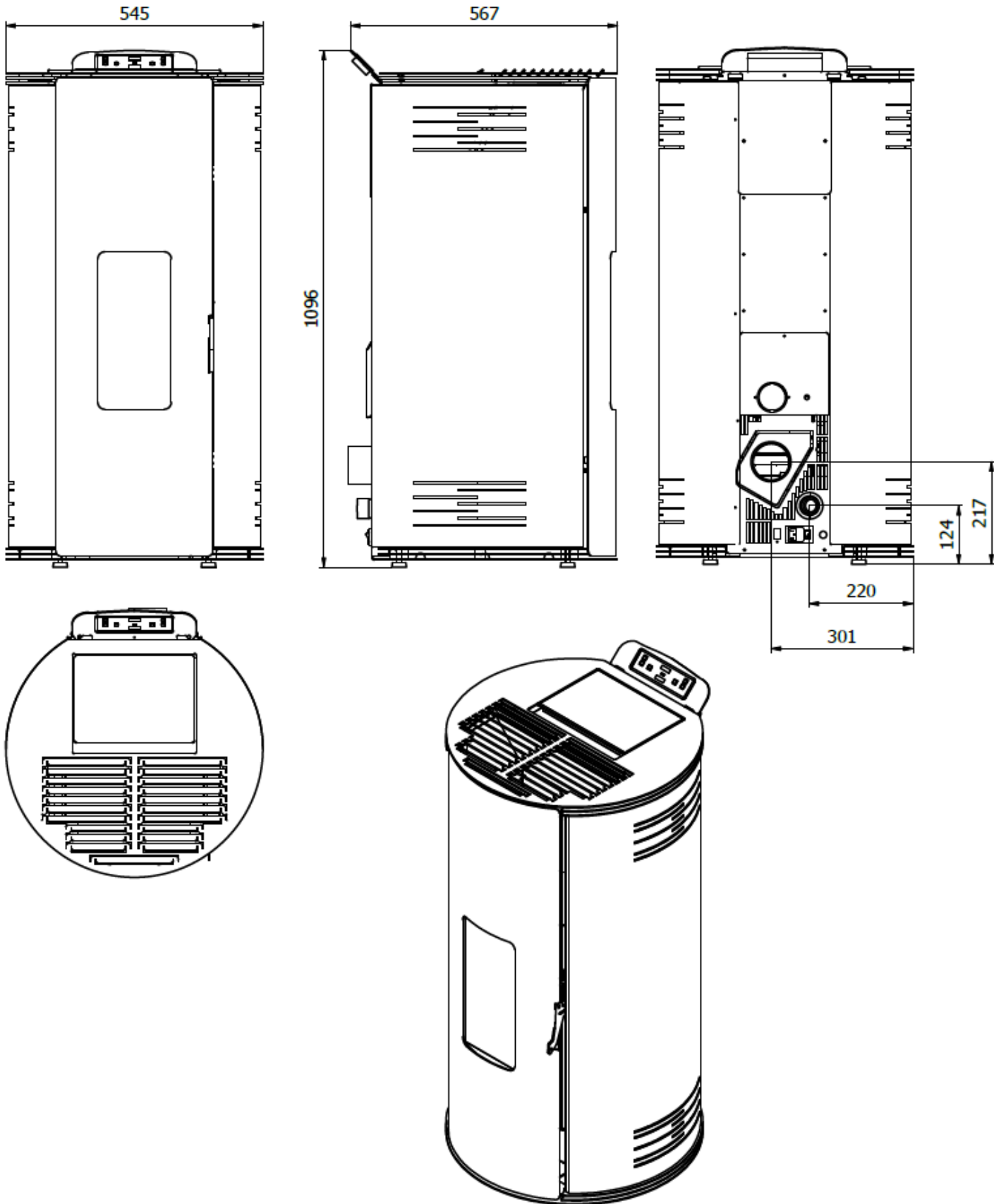

Figure 2

Contents:

1. GENERAL INTRODUCTION.....	1
1.1. SYMBOLS.....	1
1.2. DESTINATION OF USE.....	1
1.3. SCOPE AND CONTENTS OF MANUAL.....	1
1.4. STORAGE OF MANUAL.....	1
1.5. UPDATE OF THIS MANUAL.....	1
1.6. GENERAL INFORMATION.....	1
1.7. MAIN STANDARDS APPLIED AND TO BE APPLIED.....	2
1.8. LEGAL WARRANTY.....	2
1.8.1. THE FOLLOWING CIRCUMSTANCES ARE EXCLUDED FROM THE WARRANTY:.....	2
1.9. MANUFACTURER'S LIABILITY.....	2
1.10. CHARACTERISTICS OF THE USER.....	2
1.11. TECHNICAL ASSISTANCE.....	3
1.12. SPARE PARTS.....	3
1.13. IDENTIFICATION PLATE.....	3
1.14. STOVE DELIVERY.....	3
2. SAFETY WARNINGS.....	3
2.1. WARNINGS FOR THE INSTALLER.....	3
2.1.1. WARNINGS FOR THE INSTALLER.....	3
2.2. WARNINGS FOR THE MAINTENANCE TECHNICIAN.....	3
2.3. WARNINGS FOR THE USER.....	4
3. CHARACTERISTICS OF FUEL.....	5
3.1. CHARACTERISTICS OF FUEL.....	5
3.2. STORAGE OF PELLETS.....	5
4. HANDLING AND TRANSPORT.....	5
4.1. REMOVAL FROM TRANSPORT PALLET.....	6
5. INSTALLATION.....	6
5.1. GENERAL CONSIDERATIONS.....	6
5.2. SAFETY PRECAUTIONS.....	6
5.3. PLACE OF INSTALLATION OF STOVE.....	6
5.4. COMBUSTION AIR.....	7
5.5. FLUE GAS EXHAUST PIPE.....	8
5.5.1. Roof exhaust with traditional chimney.....	9
5.6. STOVE LEVELLING.....	10
5.7. CONNECTION TO UTILITIES.....	11
5.7.1. Electrical connection.....	11
5.8. OPTIMISATION OF COMBUSTION.....	11
5.9. VENTILATION.....	11
6. MAINTENANCE.....	12
6.1. MAINTENANCE.....	12
7. DEMOLITION AND DISPOSAL.....	13
8. INITIAL DISPLAY CONFIGURATION.....	13
8.1. CONNECTION TO AN EXTERNAL THERMOSTAT.....	13
9. CONTROL PANEL.....	14

9.1.	Functioning of the electronic card	14
9.2.	PARAMETERS USED BY THE STOVE USER	15
9.3.	ALARM MANAGEMENT	16
9.3.1.	Alarm dEP no (pressure alarm – alarm of the pressure switch)	17
9.3.2.	Alarm ALAr Sond (alarm of the probe for flue gases).....	17
9.3.3.	Alarm ALAr hot (alarm for excessive smoke temperature).....	17
9.3.4.	Alarm of the chamber:.....	17
9.3.5.	Alarm Alarm for overheating of the chamber or temperature of the snail distributor for pellet supply:	17
9.3.6.	Alarm for failed ignition	18
9.3.7.	Alarm for power outage.....	18
9.3.8.	Alarm ALAr Fan (alarm for discharge fan)	18
9.3.9.	„StoP FirE“ (it is not an alarm)	18
10.	PRELIMINARY OPERATIONS	19
10.1.	PELLET LOADING.....	19
10.2.	ELECTRICAL POWER SUPPLY.....	19
10.3.	IGNITION	20
10.5.	OPERATION WITH AMBIENT PROBE ON STOVE.....	20
11.	CLEANING	21
12.	INFORMATION ON DISPOSAL (THROWING AWAY) AND DISMANTLING (PULLING APART) THE STOVE	23

1. GENERAL INTRODUCTION

The product, subject of this manual, was manufactured and tested according to the safety requirements stated in the reference European directives.

This manual is intended for stove owners, installers, users and maintenance personnel of the stove and is an integral part of the product. In case of uncertainty about the content and for any clarification, contact the manufacturer or the authorised technical assistance service, stating the number of the paragraph of the topic in question.

Even partial printing, translation and reproduction of this manual are bound by the authorisation of ALFA PLAM. Technical information, graphical representations and specifications in this manual may not be disclosed to third parties.

Do not operate unless all information reported in this manual has been perfectly understood; if in doubt, always request the advice or intervention of ALFA PLAM specialised personnel.

ALFA PLAM reserves the right to change specifications and technical and/or functional characteristics of the stove at any time without prior warning.

1.1. SYMBOLS

In this manual the points of major importance are highlighted by the following symbols:

 **INDICATION:** Indications concerning the correct use of the stove and the responsibilities of the persons responsible.

 **ATTENTION:** The point in which a note of particular importance is expressed.

 **DANGER:** Expresses an important note of behaviour for the prevention of injuries or damage to properties.

1.2. DESTINATION OF USE

 The product referred to by this manual is a fire box for internal domestic heating, powered exclusively by wood pellets with automatic operation.

The stove only works with the fire box door closed.

The door must never be opened during stove operation.

 The appliance is not intended for use by persons (including children) with reduced physical, sensory or mental capacity, or without experience and

knowledge, unless they have received instructions relating to the safe use of the appliance and they are under the surveillance of a person responsible for their safety.

 The intended use specified above and the specified stove configurations are the only ones permitted by the manufacturer: only use the stove following the instructions provided.

1.3. SCOPE AND CONTENTS OF MANUAL

The scope of the manual is to provide the essential and basic rules for the correct installation, maintenance and use of the product. Strict compliance with the instructions provided herein ensures a high degree of safety and good operation of the stove.

1.4. STORAGE OF MANUAL

Preservation and consultation

This manual must be carefully stored and must be available at all times for consultation, both on the part of the user that the installation and maintenance personnel.

The installation manual is an integral part of the stove.

Deterioration or loss

If necessary, request a further copy from ALFA PLAM.

Sale of the stove

In the event of transferring the stove the user is obliged to deliver even this manual to the new owner.

1.5. UPDATE OF THIS MANUAL

This manual reflects the state of the art at the time of placing the stove on the market.

1.6. GENERAL INFORMATION

Information

In case of exchange of information with the Manufacturer of the stove, refer to the serial number and identification data indicated on the product's serial number plate.

Extraordinary maintenance

Extraordinary maintenance operations must be performed by qualified personnel authorised to intervene on the model of stove to which this manual refers.

Responsibility for the works of installation

ALFA PLAM cannot be held responsible for stove installation works, which are and remain the responsibility of the installer, who is also in charge of performing the necessary inspections on the flue and air intake, as well as ensuring the correctness of the proposed installation solutions. Furthermore, all the safety regulations provided for by the specific legislation in force in the state where the same is installed must be observed.

Use

Use of the stove is also subject, in addition to the provisions contained in this manual, to compliance with all the safety standards required by the specific legislation in force in the state where it is installed.

1.7. MAIN STANDARDS APPLIED AND TO BE APPLIED

- A) **Directive 2014/35/EU:** "Electrical equipment designed for use within certain voltage limits".
- B) **Directive 2014/30/EU:** "The approximation of the laws of the Member States relating to electromagnetic compatibility".
- C) **Directive 89/391/EEC:** "Implementation of measures to encourage improvements in the safety and health of workers at work".
- D) **Regulation EU 305/2011:** "Establishes harmonised conditions for the marketing of construction products and repeals Directive 89/106/EEC".
- E) **Directive 1999/34/EC:** "Concerning the rapprochement of the laws, regulations and administrative provisions of the member states with regard to liability for damage caused by defective products".
- F) **Standard EN 16510-1:2023** Residential solid fuel burning appliances - Part 1: General requirements and test methods
- G) **Standard EN 16510-2-6:2023** Residential solid fuel burning appliances - Part 2-6: Mechanically by wood pellets fed roomheaters, inset appliances and cookers

Ovaj proizvod je u skladu sa standardom EN 16510-2-6 o grejnim telima na drveni pelet u stambenim prostorijama. Takođe je u skladu sa srpskim zakonima kojima se implementiraju sledeće evropske direktive:

1.8. LEGAL WARRANTY

The user, in order to be able to take advantage of the legal warranty, referred to in Directive 1999/44/ EC, must strictly observe the provisions contained in this manual and in particular must:

- always operate within the stove's limits of use;
- always carry out constant and diligent maintenance;
- authorise use of the stove by persons of proven capacity, aptitude and who are adequately trained for the purpose.;
- use original spare parts specific to the stove model.

1.8.1. THE FOLLOWING CIRCUMSTANCES ARE EXCLUDED FROM THE WARRANTY:

- Improper overheating of the appliance, or use of fuels not compliant with the type and quantity indicated in the supplied instructions;
- Any parts found to be defective due to negligence or careless use, incorrect maintenance or installation that does not comply with the manufacturer's instructions (always refer to the installation and use manual supplied with the appliance);
- Further damage caused by makeshift user interventions in an attempt to solve the initial failure;
- Aggravation of damages caused by continued use of the appliance by the user once the defect has already been manifested;
- Damage caused by transport and/or handling;
- Inefficiency of chimneys, flues, or parts of the system on which the appliance depends.
- Damage caused due to tampering with the device, atmospheric agents, natural disasters, acts of vandalism, electrical discharges, defects in the electrical and/or water system.
- Failure to arrange for the annual cleaning of the stove by an authorised technician or qualified personnel, shall invalidate the warranty.
- Parts subject to normal wear such as gaskets, glass, cast iron cladding and grilles, painted, chrome-plated or gilded details, handles and electrical cables, lamps, luminous indicators, knobs, all parts that can be removed from the fire box;
- Colour variations of painted and or ceramic/coil parts, as well as flaws in the ceramic insofar as these are natural characteristics of the material and use of the product;
- Masonry works;
- Parts of the system (if included) not supplied by the manufacturer.

1.9. MANUFACTURER'S LIABILITY

! With the delivery of this manual, ALFA PLAM declines all responsibility, both civil and criminal, direct or indirect, due to:

- installation not complying with the existing regulations in the country and with the safety directives;
- partial or total non-compliance with the instructions in this manual, in particular those concerning the necessary routine cleaning;
- installation by unqualified and untrained personnel;
- use not in compliance with the safety directives;
- modifications and repairs not authorised by the Manufacturer on the stove;
- the use of non-original or non-specific parts for the stove model;
- insufficient maintenance;
- exceptional events.

1.10. CHARACTERISTICS OF THE USER

! The user of the stove must be an adult and responsible person having the knowledge needed for routine maintenance of the stove components.

 Make sure that children do not come close to the stove, while it is running with the intent to play.

1.11. TECHNICAL ASSISTANCE

ALFA PLAM provides a dense network of specialist technical assistance centres, trained and prepared directly at the company.

The head office and our sales network is at your disposal to direct you to the nearest authorised service centre.

1.12. SPARE PARTS

Use only genuine spare parts.

Do not wait until the components are worn by use before proceeding to their replacement.

Replace a worn component before its breaking favours the prevention of accidents arising from accidents caused by the sudden breakage of components which may cause serious damages to persons and objects.

Perform periodic maintenance checks as indicated in the "Maintenance" chapter.

1.13. IDENTIFICATION PLATE

The serial number plate on the stove shows all the characteristic data relating to the product, including the Manufacturer's data, the serial number and the marking .

1.14. STOVE DELIVERY

The stove is delivered perfectly packed with cardboard or wood packaging secured to a wooden platform that allows it to be moved using forklift trucks and/or other means.

Inside of the stove there is the following material:

- instruction manual.

2. SAFETY WARNINGS

2.1. WARNINGS FOR THE INSTALLER

Observe the prescriptions contained in this manual.

- The stove removal and installation instructions are reserved to specialist technicians only.
- It is always recommended that users contact our technical assistance service to request qualified technicians. In the case other technicians are involved, it is recommended to verify their actual abilities.
- Responsibility for the works carried out in the location of the machine is, and remains, attributable to the user; the latter is also required to perform checks on the proposed installation solutions.
- The user must comply with all local, national and European safety regulations.
- The appliance must be installed on floors with an adequate load bearing capacity.

 Check that the flue and air intake predispositions conform to the type of installation.

- Do not carry out flying electrical connections with provisional or non-insulated cables.
- Check that the earthing of the electrical system is efficient.

- It is prohibited to install the stove in bedrooms, bathrooms and shower rooms, in rooms where combustible materials are stored and in studio apartments.

Installation is allowed in studio apartments only with outside air intakes and if properly installed in accordance with regulations;

- Under no circumstances can the stove be installed in rooms where it is exposed to contact with water or splashes of water, as this may cause the risk of burns and short circuits.
- In accordance with fire safety laws, the clearances from flammable or heat-sensitive objects must be respected (sofas, furniture, wood cladding, etc.).
- In the case of highly flammable objects (curtains, carpet, etc.), all these clearances must be increased by 1 metre.

2.1.1. WARNINGS FOR THE INSTALLER

The person in charge of the installation, before starting assembling or disassembling of the stove, must comply with the safety precautions required by law and in particular:

- A) do not operate in adverse conditions;
- B) must operate in perfect psychophysical conditions and must check that the personal protective equipment, are intact and functioning perfectly;
- C) must wear safety gloves;
- D) must wear safety shoes;
- E) must use electrical insulated tools;
- F) must ensure that the area affected by the phases of assembly and disassembly is free from obstacles.

2.2. WARNINGS FOR THE MAINTENANCE TECHNICIAN

Observe the prescriptions contained in this manual.

 Always use individual safety devices and other means of protection.

- If the floor is made of combustible material, it is recommended to use protection in a non-combustible material (steel, glass) that also protects the front part in the event of any fuel spills during cleaning operations.
- Before starting any maintenance operation, make sure that the stove has cooled down if it has been used.
- If even one of the safety devices is found to be derated or not functioning, the stove should be considered as not functioning.
- Non-specialised users must be prevented from accessing any parts that may expose them to dangers. This person must therefore not be allowed to intervene on internal parts at risk (electrical or mechanical), even if the power needs to be disconnected
- Disconnect the power supply before working on electrical and electronic parts and connectors.

2.3. WARNINGS FOR THE USER

 Do not touch and do not approach the door glass as it could cause burns;

- Do not look at the flame for a long time;
- Do not touch the flue gas exhaust pipe;
- Do not dispose of hot ash (ensure it is completely extinguished and cooled before vacuuming or removing it);
- Do not open the glass door;
- Do not open the ash drawer (where provided);
- Do not touch and do not approach the glass of the door, it could cause burns;
- Do not look at the flame for a long time;
- Do not touch the flue gas exhaust pipe;
- Do not perform any type of cleaning;
- Do not dispose of hot ash (ensure it is completely extinguished and cooled before vacuuming or removing it);
- Do not open the glass door;
- Do not open the ash drawer (where provided);
- Do not use the appliance as a waste incinerator.
- It is prohibited to operate the product with the door open or the glass broken.
- It is prohibited to make unauthorised changes to the appliance.
- Do not use flammable liquids during ignition (alcohol, benzene, oil, etc.).
- After a failed ignition attempt, the accumulated pellets must be emptied from the burn pot before igniting the stove again.
- The pellet tank must always be closed with the lid on.
 - Before performing any type of operation, wait for the flame in the combustion chamber to fully drop until it is completely extinguished and cooled, and always detach the plug from the power socket.
 - Before performing any type of operation, the user or whoever is operating the product must have read and fully understood the contents of this installation and use manual. Errors or bad settings may cause hazardous conditions and/or irregular operation.
 - The only type of fuel that can be used is pellets.
 - Do not place laundry on the product to dry. Any clotheslines or similar must be kept at a suitable distance from the product. Fire hazard.
 - The electrical cord must never come into contact with the flue gas exhaust pipe or any other part of the stove.
 - Packaging materials are NOT toys, they may cause asphyxiation or choking risks and other health hazards! Persons (including children) with reduced physical or motor skills, or who are lacking the necessary experience and knowledge, must be kept away from the packaging. The stove is NOT a toy.
 - Children must be constantly supervised to ensure they do not play with the appliance.
 - Cleaning and maintenance must be performed by the user and cannot be carried out by children without supervision.
 - During operation, the stove reaches high temperatures: keep out of reach of children and animals and use flame-proof personal protective equipment suitable to protect against the heat.
 - If the floor is made of combustible material, it is recommended to use protection in a non-combustible material (steel, glass) that also protects the front part in the event of any fuel spills during cleaning operations.
 - During the functioning you may hear noises generated by the expansion of metal parts especially during heating/switch on, and cooling/ switch off.

2.3.1. WARNINGS AND RECOMMENDATIONS FOR THE USER

Observe the prescriptions contained in this manual.

Respect the instructions and warnings highlighted by the plates displayed on the stove.

The plates are safety devices, therefore they must always be perfectly legible. If these are damaged and unreadable, it is mandatory to replace them, requesting the original spare parts from the Manufacturer.

Use only the fuel complying with the indications given in the chapter relating to the fuel characteristics.

Follow the routine and extraordinary maintenance schedule carefully.

Do not use the stove without first performing the daily inspection as prescribed in the "Maintenance" chapter of this manual.

Do not use the stove in case of abnormal operation, suspicion of breakage or unusual noises.

Do not throw water on the stove in operation or with the intention of extinguishing the fire in the burn pot.
Do not switch off the stove by disconnecting the mains electrical connection.
Do not lean on the open door, it could compromise its stability.
Do not use the stove as a support or anchor of any kind.
Do not clean the stove until the structure and the ashes have completely cooled down.
Only touch the door when the stove is cool.
Perform all operations in maximum safety and when calm.

⚠ In case of a fire, contact the fire brigade.

⚠ In the event of stove malfunction due to non-optimal flue draught, clean it following the procedure described.
! The flue must be cleaned as described in paragraph 6.

! Do not touch the painted parts during operation to avoid damage to the paintwork.

! ANY USAGE OUTSIDE WHAT MENTIONED IN THIS MANUAL IS STRICTLY PROHIBITED.

3. CHARACTERISTICS OF FUEL

3.1. CHARACTERISTICS OF FUEL

The pellet (fig. 3.1) is composed of various types of wood, compressed using mechanical processes in accordance with environmental protection laws and is the only type of fuel intended for this type of stove.

The efficiency and thermal potential of the stove may vary depending on the type and quality of the pellets used.

We recommend the use of class A1 pellets (ISO 17225-2, ENplus A1, DIN Plus or NC 444 category "High Performance NF Pellets Biofuels Quality").

The stove is equipped with a pellet holding tank having the capacity up to 16 kg.

⚠ The loading compartment is positioned in the upper part. It must always be openable in order to load the pellets and must remain closed during stove operation.

For reasons of operating temperature control traditional wood operation is not possible.

⚠ It is forbidden to use the stove as a waste incinerator.



Figure 3.1

3.2. STORAGE OF PELLETS

! The pellets must be stored in a dry environment where the temperature is not too cold.

It is recommended to keep a few bags of pellets in the room where the stove is used, or in a nearby place provided the temperature and humidity are acceptable.

! Wet and/or cold pellets (5°C) reduce the thermal potential of the fuel resulting in the need for more cleaning maintenance of the burn pot (unburned material) and of the firebox.

Pay particular attention to the storage and handling of pellet bags. Their crushing and the formation of sawdust must be avoided.

If sawdust is introduced into the stove's tank, this could cause the pellet loading system to become blocked.

Keep the fuel at a safe distance from the stove.

The use of poor quality pellets can compromise the normal operation of the pellet stove and result in forfeiture of the warranty.

4. HANDLING AND TRANSPORT

The stove is delivered complete with all the parts provided.

Pay attention to the tendency to unbalance the stove.

The centre of gravity of the stove is moved towards the front.

Bear in mind the above also when moving the stove on the transportation support.

During lifting, avoid jerking or abrupt movements.

Make sure the forklift truck has a capacity greater than the weight of the stove to be lifted.

The full responsibility of the lifting of loads lies on the person handling the lifting equipment.

 Make sure that children do not play with the components of the packaging (e.g. films and polystyrene). Danger of suffocation!

4.1. REMOVAL FROM TRANSPORT PALLET

To remove the stove from the transport pallet, follow the instructions on page 32.

5. INSTALLATION

5.1. GENERAL CONSIDERATIONS

In the following paragraphs there are some guidelines to follow in order to obtain the maximum performance of the product purchased.

The following instructions are nevertheless subject to compliance with any laws and national, regional and municipal regulations in force in the country where the product is installed.

Installation must be performed by qualified personnel in compliance with the UNI 10683 standard.

5.2. SAFETY PRECAUTIONS

The responsibility of the works carried out in the area where the stove will be installed falls, and remains, on the user; the latter is also entrusted with the execution of the inspections related to the installation solutions proposed.

The user must comply with all local, national and European safety regulations.

The appliance must be installed on floors with adequate load bearing capacity.

The stove removal and installation instructions must only be performed by specialist technicians. It is always recommended that users contact our after sale service to request qualified technicians.

In the case other technicians are involved, it is recommended to verify their actual abilities. The person in charge of the installation, before starting assembly or disassembly of the stove, must comply with the safety precautions required by law and in particular with:

- A) do not operate in adverse conditions;
- B) must operate in perfect psychophysical conditions and must check that the personal protective equipment, are intact and functioning perfectly;
- C) must wear safety gloves;
- D) must wear safety shoes;
- E) must use electrical insulated tools;
- F) must ensure that the area affected by the phases of assembly and disassembly is free from obstacles.

5.3. PLACE OF INSTALLATION OF STOVE

On page 32 of this manual, the minimum clearances are shown, expressed in cm, which must be respected when positioning the stove with respect to combustible materials and objects.

Protect all structures which could ignite if exposed to excessive heat.

Floors consisting of flammable material such as for example: wood, parquet, linoleum, laminate or covered with carpets, must be protected by a flame retardant base under the stove, of a sufficient size. This base can be, for example, in steel, pressed slate, glass or stone and must cover the floor in the area below the stove and the flue connecting pipe and must protrude at least 50 cm in front.

The manufacturer declines all responsibility for any variations in the characteristics of the material constituting the floor under the protection.

Any wooden elements (e.g. beams) or combustible materials located near the stove must be protected with fireproof material.

 Flammable walls or elements must be kept at a distance of at least 150 cm from the stove.

 Provide a technical space accessible for possible maintenance.

Remember to respect the minimum clearance from flammable materials (x) shown on the ID plate of the pipes used for the chimney (fig. 5.2).

Pi = Flammable wall

Pp = Floor protection

 It is prohibited to install the stove in bedrooms, small rooms and environments having potentially explosive dusts in the atmosphere.

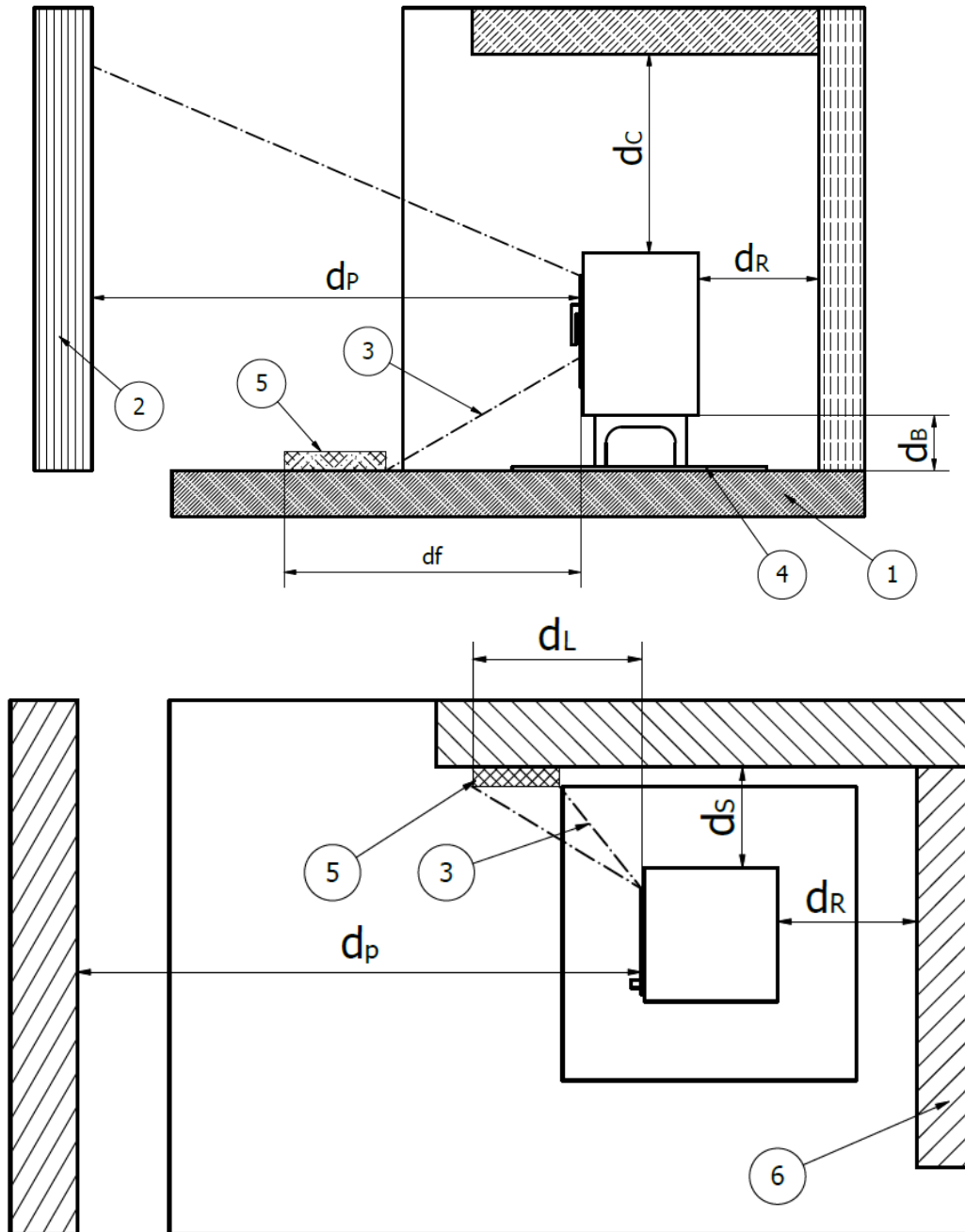

Figure 5.2 - All minimum safety clearances are listed on the technical nameplate, DO NOT use lower values than those specified (view CE MARKING INFORMATION).

Bottom (which is 0mm in case of appliances without feet)	d_B	0 mm
Floor in Front	d_F	1500 mm
ceiling	d_C	750 mm
rear	d_R	200 mm
side	d_S	200 mm
Side radiation area	d_L	1500 mm
front	d_P	700 mm

Table 4

1.	Trihedron floor
2.	Trihedron-like front plate
3.	Radiation area
4.	Floor protection plate
5.	Critical area (65K superseded due to radiation)
6.	Trihedron walls

Table 5

5.4. COMBUSTION AIR

! During use, the stove withdraws a certain quantity of air from the environment where it is located (except for products in the hermetic series, which can withdraw air directly from the outside); this air must be reintegrated through an external air intake (fig. 5.3 - PA = Air Intake).

If the rear wall of the stove is an external wall, create a hole for suction of the combustion air at a height of approximately 20-30 cm from the ground, respecting the dimensional indications provided in the product technical sheet at the end of the manual.

A non-closable permanent aeration grid must be placed external; in areas that are particularly windy and exposed to weathering, provide rain and wind protection.

Make sure the air intake is positioned so that it is not accidentally obstructed.

If it is impossible to create the external air intake in the rear wall of the stove (non-perimeter wall) a hole must be created in an external wall of the room where the stove is positioned.

If it is not possible to create the external air intake in the room, an external hole can be created in an adjacent room provided it communicates permanently with a transit grille. (fig. 5.3a - C = Box, G = Grille, S = Shutter)

The UNI 10683 standard prohibits the taking of combustion air from garages, combustible material warehouses or activities with the risk of fire.

If there are other heating appliances in the room, the combustion air intakes must guarantee the necessary volume of air for correct operation of all the devices.

In the event that one or more extraction fans (suction hoods) are present and functioning in the room where the stove is located, combustion malfunctions due to the lack of combustion air could occur.

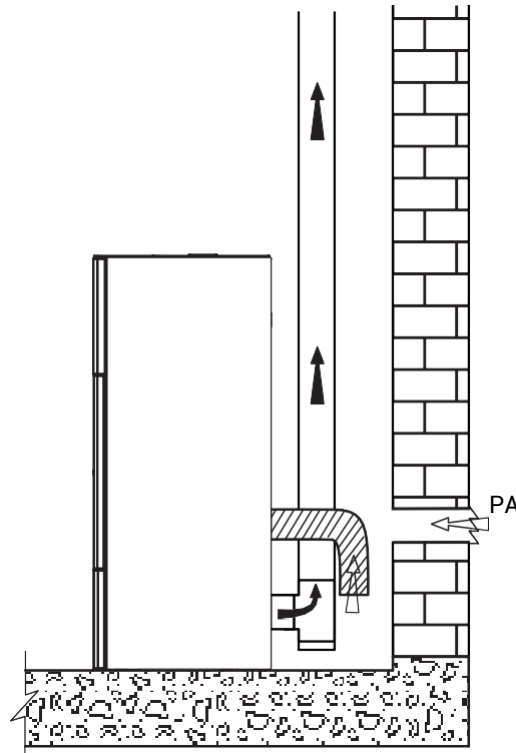

Figure 5.3

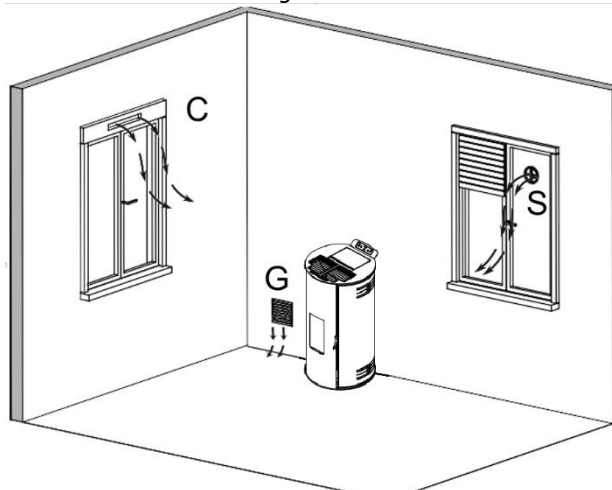

Figure 5.3a

Product images are purely indicative.

5.5. FLUE GAS EXHAUST PIPE

The stove works with the combustion chamber in a vacuum, therefore it is essential to ensure the flue gas exhaust pipe is properly sealed.

The stove must be connected to its own dedicated flue system, suitable in ensuring the proper dispersion of the combustion products in the atmosphere.

The components that make up the flue system must be declared suitable for the specific operating conditions and provided with CE marking.

! It is mandatory to create a first vertical section of a minimum 1.5 meters to guarantee correct expulsion of the flue gases. It is advisable to make a maximum of 3 changes of direction, in addition to that resulting from the rear connection of the stove to the chimney, using 45-90° bends or T-fittings (fig. 5.4).

Always use a T-fitting with an inspection cap at each horizontal and vertical variation of the flue gas exhaust pipe.

☞ On the first T, at the exit of the flue gas outlet of the stove, it is necessary to connect a pipe at the bottom in order to evacuate any condensate that may form in the chimney (Fig. 5.6a).

The horizontal sections must have a maximum length of 2-3 m with an upward slope of 3-5% (fig. 5.6).

Anchor the pipes with suitable collars to the wall.

The flue gas exhaust connection **MUST NOT** be connected:

- to a chimney used by other generators (boilers, stoves, fireplaces, etc.);
- to air extraction systems (hoods, vents, etc.) even if "intubated".

It is forbidden to install shut-off and draught valves.

The exhaust of the combustion products must be provided on the roof.

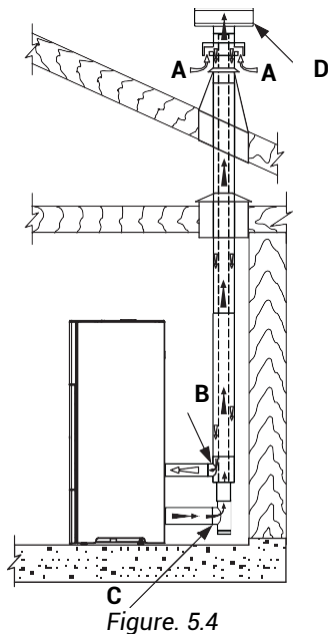

Figure. 5.4

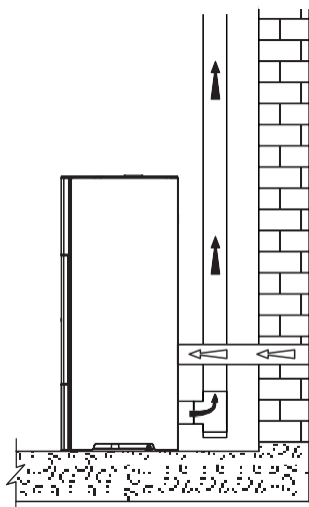

Figure. 5.5

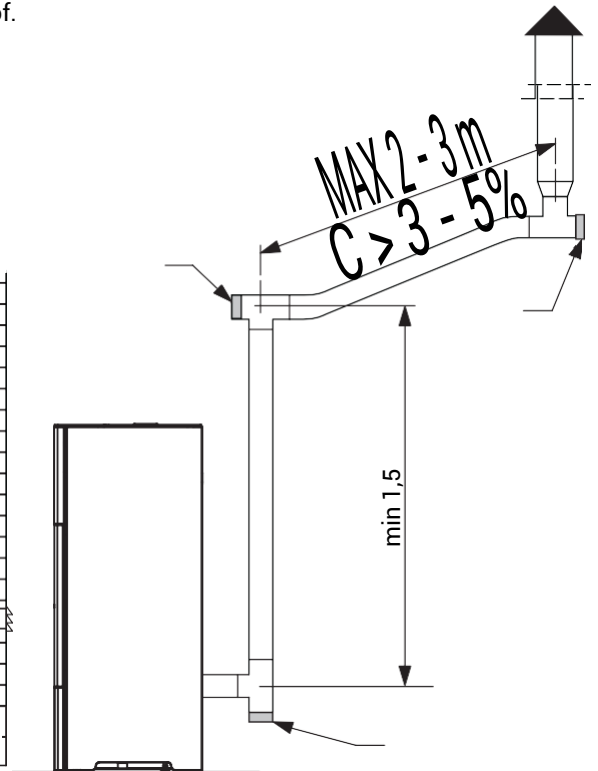

Figure. 5.6

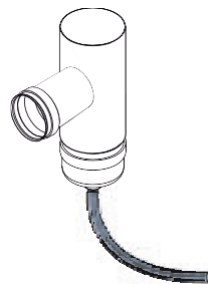

Figure. 5.6a

5.5.1. Roof exhaust with traditional chimney

The flue for the expulsion of flue gases must be developed in compliance with the UNI 10683- EN 1856-1-2- EN 1857- EN 1443- EN 13384-1-3- EN

12391-1 standards both regarding the dimensions and the materials used in its construction.

DILAPIDATED chimneys, made with unsuitable materials (fibrocement, galvanized steel, etc... with rough and porous internal surfaces) are not allowed and compromise the proper operation of the stove.

Flue gases can be released through a traditional chimney (Fig. 5.8) provided the proper maintenance of the chimney is guaranteed;

! For chimneys with a larger section, it is necessary to "intubate" the chimney with steel piping (of a diameter based on the path), which must be properly insulated (fig. 5.9).

Check that the connection to the chimney in masonry is properly sealed.

! In case of pipes that pass through wooden roofs or walls, it is recommended to use special certified ducting kits commonly available on the market.

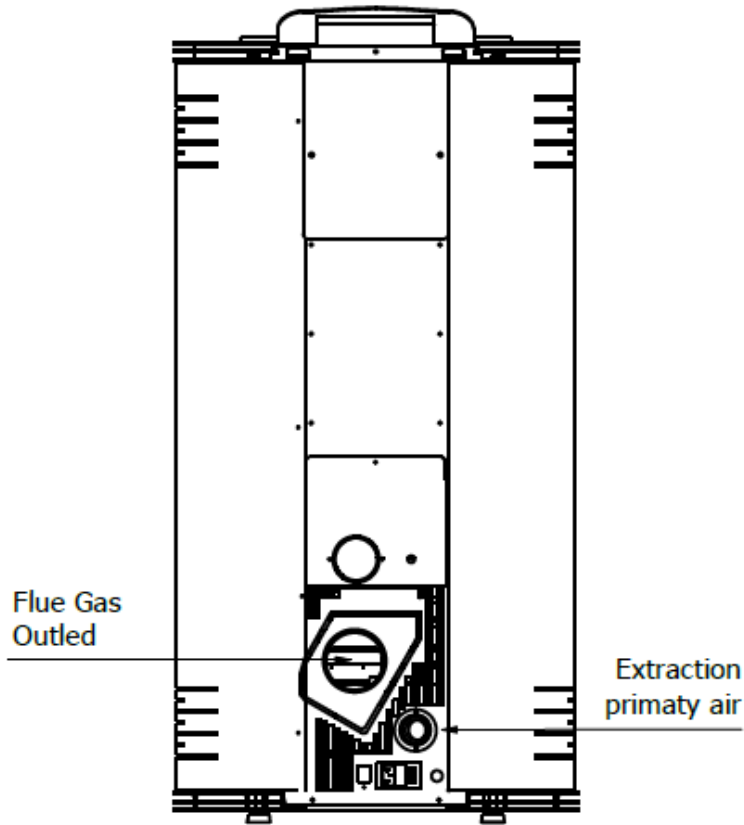

Figure. 5.7

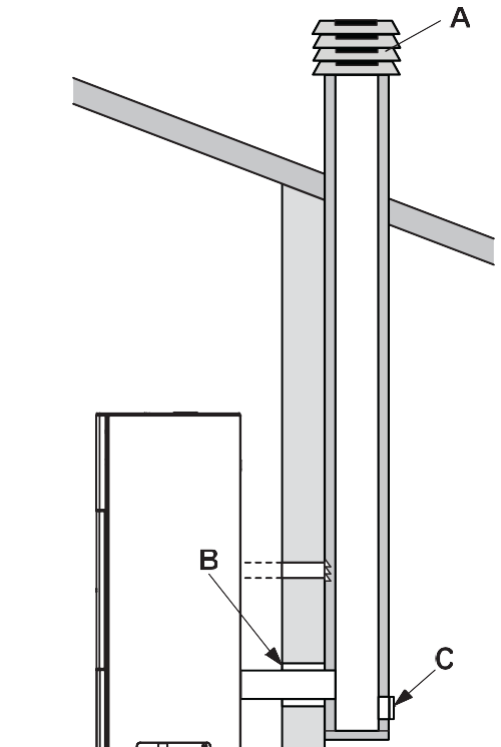

Figure. 5.8

- A) Windproof chimney stack
- B) Seal
- C) Inspection

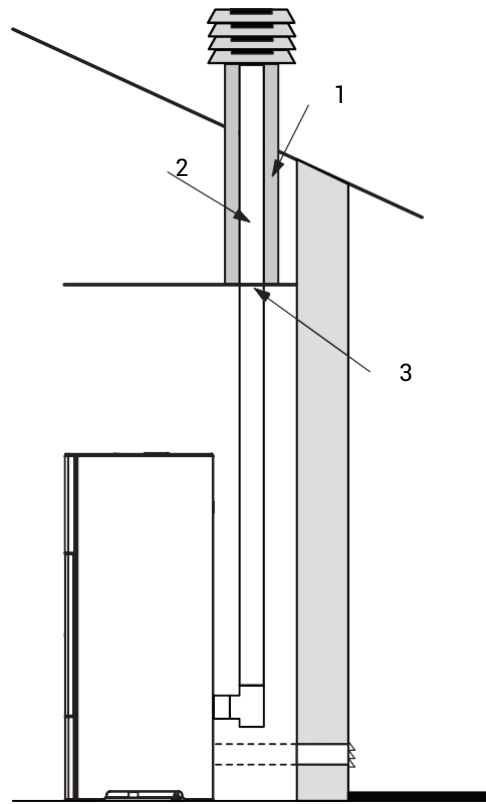

Figure. 5.9

- 1) Vermiculite and/or rock wool.
 - 2) Steel piping.
 - 3) Closing panel.
- Product images are purely indicative

5.6. STOVE LEVELLING

The stove must be levelled, with the help of a spirit level, by regulating the adjustable feet (if included) fig. 5.10).

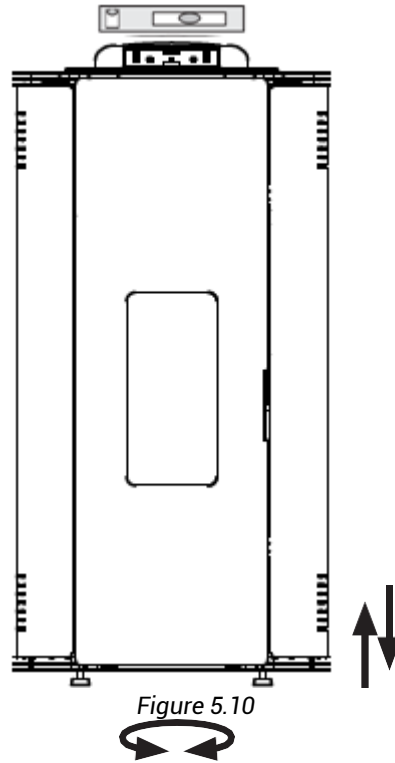

Figure 5.10

5.7. CONNECTION TO UTILITIES

5.7.1. Electrical connection

It is sufficient to connect the stove to the electrical system using the supplied plug.

The electrical connection (plug) must be easily accessible even after installing the stove.

! If the power cord is damaged, it must be replaced by the technical assistance service or by a qualified technician in order to prevent any risk.

5.7.1.1 Earthing

The system must be earthed and equipped with a differential switch in accordance with legislation in force (fig. 5.11).

! Make sure the power cord does not come into contact with hot parts.

! The flue gas exhaust pipe must have its own earth connection.

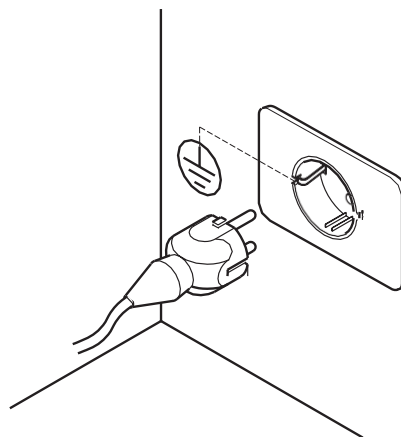

Figure. 5.11

5.8. OPTIMISATION OF COMBUSTION

Best combustion depends on a variety of factors (type of installation, operating and maintenance conditions, type of pellets, etc...)

Upon the first ignition, the stove's combustion can be optimised.

Generally speaking, if there is a lot of residue in the burn pot at the end of combustion, it is recommended to adjust the combustion configuration (increasing the value) until the most suitable solution is found.

See sections 9.17- 9.18 - 9.19.

5.9. VENTILATION

The stove is equipped with ventilation.

The air pushed by the fans keeps the appliance at a low enough temperature, thus avoiding excessive stress on the materials of which it is composed.

Do not close the hot air outlet vents with any objects or the stove will overheat!

The stove is not suitable for cooking food.

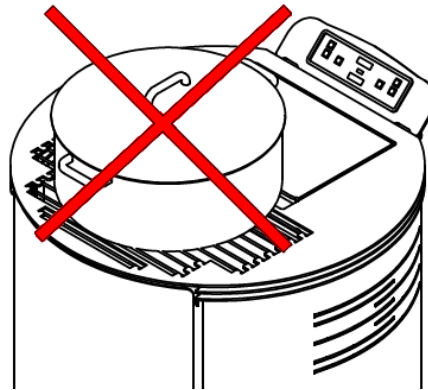



Figure. 5.12

 **ATTENTION:** Do not cover the air vents.

6. MAINTENANCE

(by an authorised technical assistance centre)

6.1. MAINTENANCE

Maintenance operations must be performed by an authorised technical assistance centre.

Before performing any maintenance operation, take the following precautions:

- Make sure that all the parts of the stove are cold.
- Make sure that the ashes are completely extinguished.
- Use personal protective equipment provided for by Directive 89/391/EEC.
- Make sure that the general line switch is turned off.
- Make sure that the power supply cannot be accidentally reactivated. Remove the plug from the wall socket.
- Always use appropriate equipment for maintenance.
- Once the maintenance or the repair operations are completed, before re-commissioning the stove, install again all the protections and restart all the safety devices.

6.1.1. FLUE SYSTEM MAINTENANCE

To be performed at least once a year, or every 40 tons of burned pellets.

If there are horizontal sections, it is necessary to check and remove any ash and soot deposits before they block the passage of the flue gases.

In the event of failure or inadequate cleaning, the stove may have functional problems such as:

- bad combustion
- glass blackening
- blockage of the burn pot with accumulation of ash and pellets
- risk of flue catching fire.

6.1.2. STOVE MAINTENANCE

It must be carried out at least once a year, or each time the stove indicates that maintenance is required.

During the maintenance operation, the technician must:

- clean the flue gas passage area thoroughly and completely;
- check the condition of all the seals and make sure they work properly;
- check the condition of all internal components and make sure they are clean;
- make sure the flue gas outlet connection is sealed and clean;
- remove any deposits of pellet residues in the tank;
- make sure that the stove is working properly;
- reset any warnings or alarms
- for easy access to the fan (A), simply remove the lid (B) by adjusting the two screws (C) (Fig. 5.13).

6.1.3. GASKET REPLACEMENT

If the gaskets of the fire door, tank or flue gas chamber become worn, they must be replaced by an authorised technician in order to guarantee the proper operation of the stove.

 **ATTENTION:** Use only original spare parts.

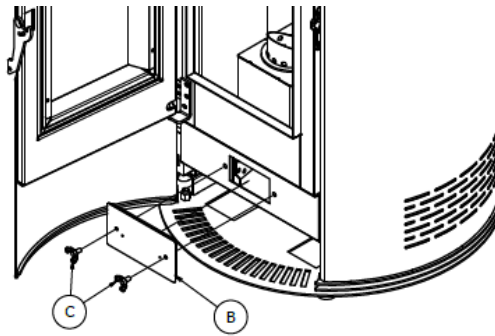

Figure. 5.13

CONTROL AND MAINTENANCE PROGRAMME	EACH IGNITION	EACH WEEK	1 MONTH	1 YEAR (y)
BURN POT	X			
ASH DRAWER		X		
GLASS		X		
ROOM FAN EXTRACTION GRILLE		X		
BOILER			X	
HEATING ELEMENT SLEEVE		X		
EXHAUST MANIFOLD			X	
DOOR AND BURN POT GASKETS*				X
FLUE DUCT*				X
FANS*				X

(*) By an authorised technical assistance centre.

(a) At least once a year or every 4 tonnes of burnt pellets.

7. DEMOLITION AND DISPOSAL

Demolition and disposal of the stove is the exclusive responsibility of the owner who must act in compliance with the laws on safety, respect and protection of the environment, in force in the country where the stove is installed.

Decommissioning and disposal can be entrusted to a third party, provided to always use companies authorised for recovery and elimination of the materials in question.

 **INDICATION:** follow always and in any case the regulations in force in the country of installation for the disposal of materials and possibly for the disposal report.

! **ATTENTION:** All disassembly operations for the demolition must take place with the stove off and the power supply disconnected.

- remove the entire electric system;
- separate the accumulators in the electronic cards;
- the stove structure can only be demolished by authorised companies;

! **ATTENTION:** The abandonment of the stove in accessible areas constitutes a serious danger for people and animals. Any liability for damage to people and animals always falls on the owner.

At the time of demolition the CE marking, this manual and any other documents relating to this stove should be destroyed.

The crossed out wheellie bin symbol that appears on the label of the appliance indicates that the product at the end of its useful life must be disposed of separately from other waste.

Within the meaning of art.13 of Legislative Decree no. 151 of 25 July 2005 implementing the Directive 2002/96/EC of 23 February 2003 on Waste Electrical and Electronic Equipment relating to the measures and procedures designed to prevent the production

of waste electrical and electronic equipment, called WEEE, promoting the reuse, recycling and other forms of recovery so as to reduce the quantity to be disposed of and improving the intervention of the parties involved in the life cycle of such products.

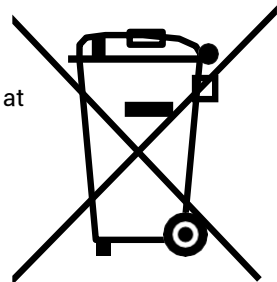

8. INITIAL DISPLAY CONFIGURATION

When the stove is turned on, the display shows the operating status. During the initial start-up, the display shows the stove model and the installed firmware release.

The stove must be powered using the ON/OFF safety switch located at the back; after a few seconds it is ready for ignition.

The stove will modulate its power based on the set ambient temperature, which is detected by the probe on-board the stove.

8.1. CONNECTION TO AN EXTERNAL THERMOSTAT

Function not active in this version.

9. CONTROL PANEL

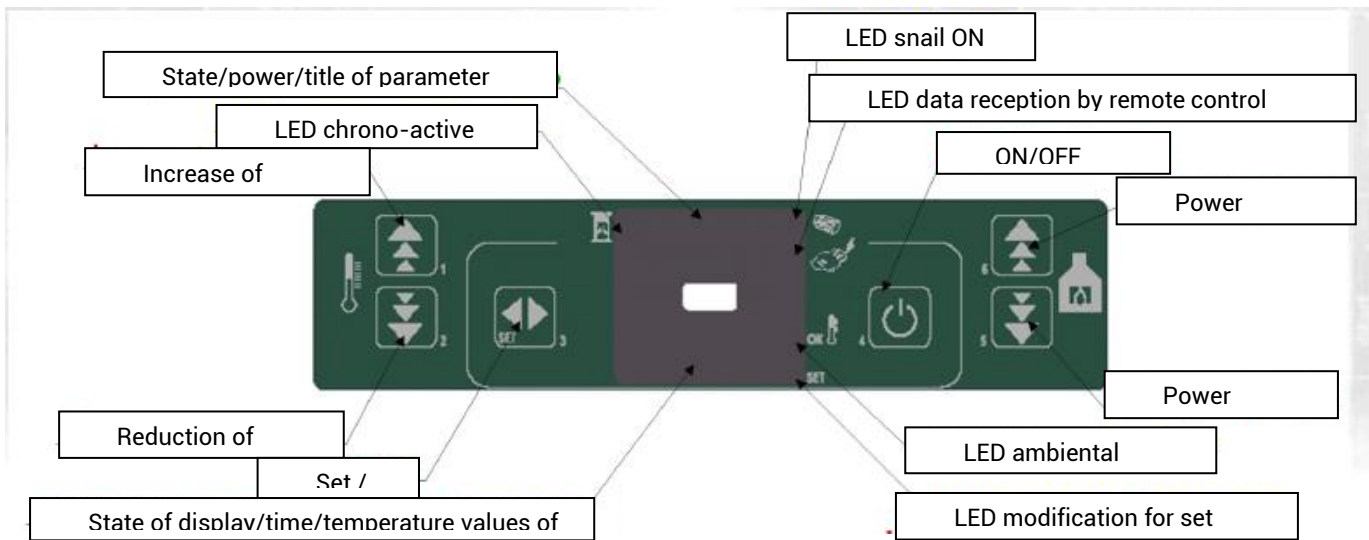

Figure 9.1 Display

Button 1: it increases the room temperature, shows the temperature of the chamber

Button 2: reduces the room temperature

Both these buttons have program functions.

Button 3: modification of the temperature and program functions

Button 4: switched on/ switched of (ON / OFF) and exit from programs

Button 5: reduces the heat capacity from 5 to 1

Button 6: increases the heat capacity from 1 to 5

WARNING

Automatic programming of the ventilation with values from 1 to 5 has been factory adjusted and can be changed only by authorized professional repairmen, and factory experts. They are informed from each separate case.

9.1. Functioning of the electronic card

When it is already connected to the power supply, you should turn the switch which is located at the back side of the stove into position 1. Then the following indication as shown in figure 9.2 appears:



Figure 9.2

In order to start the stove, press button 4. Shortly after this, the command to the electronics will put the stove into a state of calibration, that is, preparation for work and the message shown in figure 9.3 appears on the display. The suction device will be switched off for about 15 seconds, that it will be switch on again for maximum 7 seconds.



Figure 9.3

Upon termination of this stage, which lasts about 20 seconds, the message "LOAD WOOD" appears as shown in figure 9.4. The snail loader loads the pellets and the ignition heating element is on. This is shown on the display of the control keyboard through the previously described LED lamps.

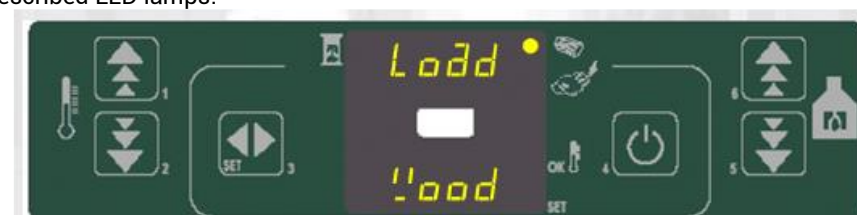

Figure 9.4

When the temperature is sufficiently high (after about 15 minutes), reach in accordance with a certain coefficient (about 3°C per minute), the electronic command prepares the fuel ignition and the next stage of operation follows, flame stabilization and

then the display of the command board shows the message "FIRE ON" (activated flame) as in figure 9.5. The tangential fan (alternator) switches on at that moment as well.



Figure 9.5

Upon termination of the stabilization stage (the standard duration is about 2 seconds), the control of the electronic unit goes to an operation mode, showing the selected heating power (which may be changes by means of the buttons 5 and 6) and the ambient temperature Figure 9.6.



Figure 9.6

In this stage the buttons 5 and 6 adjust the stove energy from 1 to 5, provided that the ambient temperature is less than the determined set temperature*.

Otherwise, the heating energy is set to a minimum.

* Actually, the stove is set to an ambient temperature. After reaching the desired temperature (manually adjusted – look at the chapter with description of the modification of ambient temperature), the stove adjusts its operation to a minimum and in that case it is not possible to change the heating energy.

If the pellet fuel does not ignite, the stove will try once more to ignite the fuel. If the pellet ignition does not succeed once again, this will be indicated with an alarm.

The speed of the device for air suction and the fan, as well as the time required for furl ignition through the heating element, are parameters which can be adjusted only by authorized professional repairmen, factory experts.

Once connection to the power supply is established, upon stoppage of electricity for a certain period of time, the control of the electronics enables discharge of the remaining smoke with an increased speed of the air suction device and then the display shows the following message "COOL FIRE". Once the cooling is over, then the fuel ignition starts once again.

IMPORTANT NOTICE

The stove normally switches on after about 15 minutes, with a good quality of the pellet fuel and with an ambient temperature of 11 degrees. If the ambient temperature is lower and the spark plug functions normally, cancellation of the stove ignition may occur. If this happens, you should switch off the stove by pressing the button 4. Then take remove and empty the cast burner where the pellets fall and combust. Return the cast burner to its position in the stove and once again start (restart) the stove by pressing button 4 for few seconds.

- **In order to change the set ambient temperature** (this is the desired temperature of the room where the stove is located), at any moment press the button 3 and use the buttons 2 and 1 to adjust the temperature indicated on the lower display. When the button 3 is pressed, the lower part of the control board indicates the set ambient temperature (the one you would like to achieve).

- **In order to check the stove temperature**, press button 1. The lower display on the control board shows the temperature, while the upper display shows the number of rotations of the smoke suction motor.

- **Switching off of the stove** occurs once you press button 4. The upper display shows the message OFF (switched off) and the flow of pellet fuel into the firebox is stopped. After cooling, the tangential fan switches off (stops working) and after 10 minutes from the moment of cooling, the suction device switches off as well. The switching off speed of the smoke suction device is a parameter which may be set only by an authorized repairman.

NOTE: Even when the stove is cold, switching off of the smoke suction device occurs after about 10 to 15 minutes.

For this reason DO NOT switch off the stove from the main switch (0-1) one the stove is switched off (OFF). Wait until the switching off cycle is finished, that is, after cooling of the stove as it is previously described.

9.2. PARAMETERS USED BY THE STOVE USER

(Press button 3 to access the parameters)

Every time when you press this button you may get one of the following parameters with the corresponding functions given here:

Use buttons 1 and 2 to change the value of the parameters

UT01: day in the week. Day 1 ... Day 7 or OFF to show that the programming is switched off

UT02: change the current hours

UT03: change of minutes

UT04: button for access to technical parameters (reserved). DO NOT TOUCH. THE PARAMETERS ARE FACTORY ADJUSTED AND RESERVED FOR EXPERTS AND TECHNICAL STAFF OF THE STOVE MANUFACTURER.

UT05: change of the starting time (program 1) in stages of 10 minutes

UT06: change of the switching off time (program 1) in stages of 10 minutes

UT07: change of program 1, active / inactive, days in the week with the button 2 and going over through the days with button 1. Confirm and proceed with button 3.

UT08: change of the starting time (program 2) in stages of 10 minutes

UT09: change of the switching off time (program 2) in stages of 10 minutes

UT10: change program 2, active / inactive, days in the week with button 2 and going over through the days with button 1.

Confirm and leave the parameters with button 3.

UT11: change of the starting time (program 3) in stages of 10 minutes

UT12: change of the switching off time (program 3) in stages of 10 minutes

UT13: change program 3, active / inactive, days in the week with the button 2 and going over through the days with button 1.

Confirm and proceed with button 3.

UT14: change of the starting time (program 4) in stages of 10 minutes

UT15: change of the switching off time (program 4) in stages of 10 minutes

UT16: change program 4, active / inactive, days in the week with button 2 and going over through the days with button 1.

Confirm and leave the parameters with button 3.

NOTE: In order to go to the next parameter, use the button 3 (adjustment), button 1 for increasing and button 2 for reduction.

NOTE: You can leave the program at any time by pressing button 4.

The stove programming enables that you program the starting and the switching off of the stove four time in one day, seven days in the week (with the day 1 that indicates the day when the first programming has been performed).

Setting the time

You can set the operation of the time and it can be seen on the lower red indicator of the keyboard. When you're programming the operation of the time, it functions also when the stove is not switched on since it is charged by a battery.

You must adjust the time if you want to program the stove operation, that is, if you want to program automatic switching on and switching off of the stove.

The procedure for adjustment of the time is the following:

Press the button 3 twice until the flickering message **UT01** appears.

At that moment, press the buttons 1 and 2 to adjust the day in the week (day 1 corresponds to Monday, continuing further to day 7 which corresponds to Sunday). Adjust the day when you make the adjustment of the time (for example, if it is Monday, set DAY1).

Then press the button SET once you set the day. The display shown a flickering message **UT02**. Now here you can set the time by using the buttons 1 and 2. After you press the button SET one more time (to confirm the inserted time), the flickering message **UT03** appears and now you can change the minutes of the time again by using the buttons 1 and 2.

After setting the minutes, press the button SET once again to get the message **UT04** which corresponds to the programming of the technical parameters (use only authorized repairmen).

Once you have adjusted and confirmed the operation of the clock, the LED lamp 1 (left, up) on the keyboard will switch on and will stay on. Temporarily recontrol the accuracy of the clock and if it is disrupted you can adjust it once again according to the manner described above.

In order to come out of the program at any time, press once the button for switching off the stove (button 4) in duration of not less than 2 seconds.

Automatic starting and switching off of the stove

If you want automatic starting and switching off of the stove, the clock must be adjusted as described.

Once you've adjusted the clock and reached the parameter **UT04**, press SET once again to go to **UT05**. Now here you can select the time of starting for the program of the first automatic starting of the stove, again by using the buttons 1 and 2.

We would like to remind you that the stove starting and switching off can be programmed four times in one day, seven days in the week. The first cycle of starting/switching off takes place through the program 1, with presented parameters **UT05**, **UT06** and **UT07**. Another cycle of starting/switching off take place through the program 2 and it can be modified through the parameters **UT08**, **UT09** and **UT10**. The third program is performed with the parameters **UT11**, **UT12**, **UT13** and the fourth program is performed through the parameters **UT14**, **UT15** and **UT16**.)

Once you adjust the starting time for the first program, use the button SET to move to parameter **UT06**, where you can adjust the switching off time of the stove, again by using the buttons 1 and 2.

Once you confirm the selected switching off time by using the button SET, then you go to parameter **UT07**, where you determine, that is, you set the days in the week when the previously defined program of starting / switching off will be active, that is, when it will act.

Then the message "ON1" appears. This means that on day 1 (previously defined with the parameter **UT01**) the first program of starting/switching off will be active i.e. it will act at that moment. In order to switch off the automatic starting, switching off of the stove on that day, now press the button 2 and the display will show the message OFF1 (switched off programming for that day).

If instead of that you press the button 1, go to day 2 ("ON2") where in the same manner you can activate or switch off the first starting program with button 2.

Continue in the same manner to activate/deactivate the programs for the remaining days in the week.

After programming the starting/switching off of the stove operation for different days in the week, once again press the button SET in order to get access according to the sequence of parameters **UT08**, **UT09** and **UT10**, which represent the parameters for adjusting another program for starting/switching off the stove, which can be memorized.

In order to turn off, that is, to delete all weekly and daily programs for starting and switching off of the stove for program 2 (when there is no more flickering of the UT parameter), press the button SET until **UT10** appears on the display, than select OFF from the given selection by pressing the buttons 1 or 2 for all 7 days, separately for each day.

If you want to turn off, that is, to delete the programmed starting and switching off of the stove of the program 1, you should press SET to get to **UT07**, for program 3 to get to **UT13**, for program 4 to get to **UT16** and in the described manner as for program 2 (**UT10**) cancel all programs for starting and switching off of the stove for all days (everywhere it should be OFF-switched off).

9.3. ALARM MANAGEMENT

An alarm signal (meaning that the stove informs about the occurrence of a certain problem with a sound signal) appears in the following cases:

ORIGIN OF THE ALARM	PRIKAZ NA DISPLEJU
Probe for smoke temperature	ALARM SOND FUMI
Probe for smoke temperature	ALARM HOT TEMP
Failed ignition	ALARM ACC NO

Stoppage of stove operation	ALARM NO FIRE
Lack of power supply	ALARM NO RETE
Safety thermostat of the auger (spiral)	ALARM DEP NO
Thermostat for general safety	ALARM DEP NO
Pressure switch	ALARM DEP NO

In case of irregularities of the operation, the following procedure is activated:

- 1) The system for automatic pellet filling switches off
 - 2) The smoke discharge fan operates with a full maximal capacity for maximum twenty minutes.
- Before switching the stove once again, wait that it gets completely cold and then press the button „4“ (on/off).
If the stove is not cold, the message „AttE“ is shown as in figure 9.8.



Figure 9.8

9.3.1. Alarm dEP no (pressure alarm – alarm of the pressure switch)

It occurs when irregularities occur related to:

The flue pipe hardly pulls which causes poor, insufficient pressure.

If the alarm continues occurring, check whether the stove or the chimney should be serviced.

The smoke pressure switch controls the negative pressure in the stove chamber due to improperly closed door or ash box, or due to some obstacles in the smoke outlet. In this case, the display shows the message **ALAr dEP no** (Figure 9.9), the smoke motor functions maximally and then it switches off after 10 minutes.



Figure 9.9

9.3.2. Alarm ALAr Sond (alarm of the probe for flue gases)

It appears when an error occurs in the smoke detection probe, when the probe is broken or it is not connected.

The stove begins the switching off procedure while the alarm is switched on.

Alarm of the smoke probe: if some malfunction occurs at the smoke probe, the display shows the message "SOND FUMI ALAR", and in this case the fan and the smoke suction device function with full power.

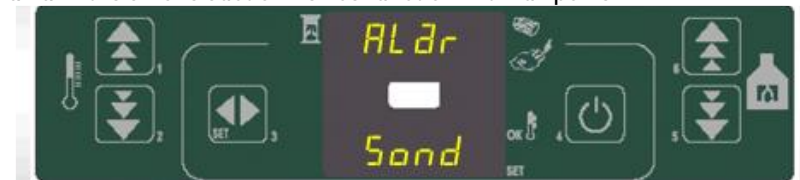

Figure 9.10

9.3.3. Alarm ALAr hot (alarm for excessive smoke temperature)

It occurs when the probe for flue gases indicates too high temperature (more than 280°C)

The stove begins the switching off procedure while the alarm is on.



Figure 9.11

9.3.4. Alarm of the chamber:

This alarm appears when the temperature of the stove chamber is too high and then the message "HOT TEMP ALAR" appears. In order to prevent the occurrence of this alarm to certain temperature limits, the smoke suction device and the exchanger must function at their maximum, and the fuel pellets are minimally inserted. In order to return to normal operation, press the button 4, for 3 seconds until the boiler returns back to ON (switched on) state.

9.3.5. Alarm Alarm for overheating of the chamber or temperature of the snail distributor for pellet supply:

It occurs if the main safety thermostat from 80°C or 180°C reads a temperature higher than the allowed. The message „ALAr dEP no“ appears (Figure 9.12) and the system stops. This alarm appears when the temperature of the chamber or the temperature of the funnel for pellet inlet is too high, and in this case the following message appears "ALAr dEP no". This is one additional safety mechanical device. In order to return to normal operation, you need to wait for the stove to get' cold (the fans

for smoke and for cooling are in function). This cooling lasts about twenty minutes. Then restore the function of the safety thermostat that has blocked the stove operation (by unscrewing the plastic cover and manually press the thermostat button until a silent metal sound is heard) which is located in the lower back part, above the main switch (0-1) and then press the button 4 in a duration of 3 seconds until the stove returns back to it ON (switched on) position. The upper thermostat blocks the stove operation when the stove chamber heats at 180°C and the lower one when the case of snail transmission heats at 80°C.

NOTE: If one of these two last alarms is active, make sure that the chamber is not clogged with ash and that the flue is not partially clogged.



Figure 9.12

9.3.6. Alarm for failed ignition

It triggers when the ignition stage failed and the following message appears „ALAr Acc no“ (Figure 9.13). The switching off procedure immediately activates.



Figure 9.13

9.3.7. Alarm for power outage

When the stove is switched on, a power outage stops the operation of the electrical devices on the stove. When the power supply returns, an alarm signalization occurs as shown in figure 9.14:



Figure 9.14

9.3.8. Alarm ALAr Fan (alarm for discharge fan)

If the smoke discharge fan does not function well, an alarm occurs – ALAr FAn FaiL (Figure 9.15). The stove begins the procedure of switching off while the alarm is on.



Figure 9.15

9.3.9. „StoP FirE“ (it is not an alarm)

StoP FirE“ mode can be activated in adjusted intervals, during normal operation. Cleaning of the stove is performed. A message „StoP FirE“ is shown (Figure 9.16).

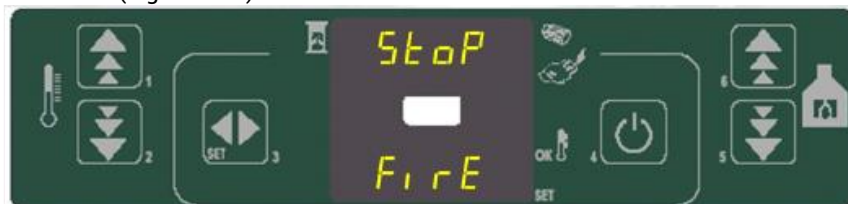

Figure 9.16

By pressing the button 4 you can delete, that is, remove a message from the display. The alarm signals are followed by a sound signal.

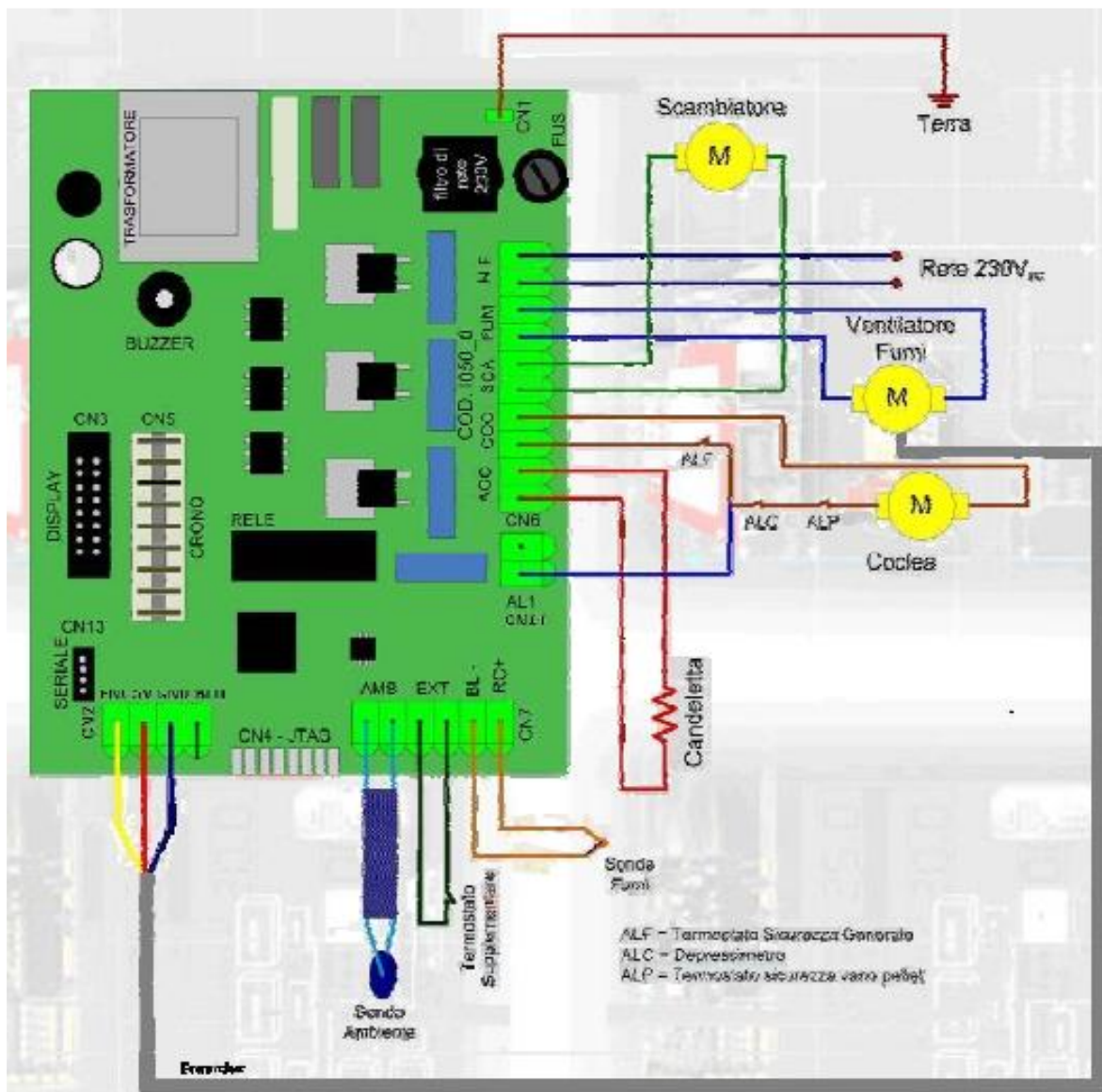

Figure 9.17. Electronic card

10. PRELIMINARY OPERATIONS

10.1. PELLET LOADING

The first operation to be carried out before turning the appliance on is to fill the tank with fuel (pellets), preferably using a scoop.

Be careful not to touch the hot parts if fuel refilling is carried out with the stove running.

Do not empty the bag directly into the tank to avoid loading sawdust or other foreign elements that could compromise correct functioning of the stove and to avoid dispersing the pellets outside the tank itself.

Be sure to close the lid of the tank well after loading the pellets.

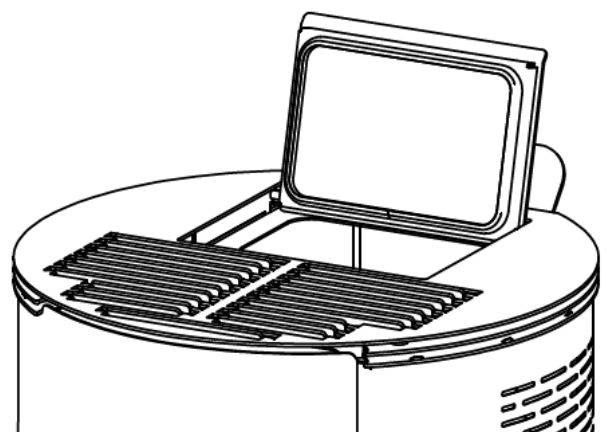

Figure 10.1

10.2. ELECTRICAL POWER SUPPLY

Connect the stove to the mains power, operate the ON switch on the back of the stove, positioning it to "I" (fig. 3.2). If the connection is properly made, the display will light up.

During long periods of non-use, it is recommended to position the switch on the back of the machine to OFF (O).

Do not touch the control panel when the stove is being powered.



Figure 10.2

10.3. IGNITION

⚠ Before each ignition, make sure that the burn pot is completely empty and correctly positioned in its seat.

To turn on the stove hold the ⏻ key pressed for a few seconds.

⚠ Avoid manually turning on the stove if the automatic ignition system is compromised.

During initial ignition of the stove it is possible to generate unpleasant smells or fumes caused by the evaporation or drying

! of some of the materials used. This phenomenon will gradually disappear.

• During the first lightings, we recommend that you keep the premises well ventilated.

⚠ Do not pour pellets directly into the burn pot.

10.4. POWER OFF

To turn off the stove hold the ⏻ key pressed for a few seconds.

👉 It is advisable to wait for the stove to completely cool before re-igniting it again.

⚠ The stove should always be turned off strictly in accordance with the above, and absolutely not by disconnecting it from the mains power.

⚠ **ATTENTION: Do not insert fuel through the aeration outlets.**

10.5. OPERATION WITH AMBIENT PROBE ON STOVE

The stove can be switched on/off manually or in a programmed way.

The stove modulates the power depending on the ambient temperature measured by the on-board probe (that is, the stove tries to maintain the desired temperature, consuming as little as possible).

If the user has enabled the "Standby" function, rather than modulate, the stove will turn off when the set temperature is reached, then re-ignite when the ambient temperature falls below the set delta.

The desired ambient temperature can be set using the keys 🖱 + -.

PROBLEM	CAUSE	SOLUTION	
The control display won't turn on	The stove is without power	Check that the plug is connected to the mains.	USER
	The safety fuses in the electrical socket are blown	Replace the safety fuses in the electrical socket (3.15A-250V).	TECHNICIAN
	Faulty control display	Replace the control display.	TECHNICIAN
	Faulty flat cable	Replace the flat cable.	TECHNICIAN
	Faulty circuit board	Replace the circuit board	TECHNICIAN
Pellets are not reaching the combustion chamber	Tank empty	Fill the tank.	USER
	Fire door open or pellet door open	Close the fire door and pellet door and check that there are no pellet granules along the gasket.	USER
	Clogged stove	Clean the flue gas chamber.	USER
	Auger blocked by a foreign object (such as nails)	Clean auger.	TECHNICIAN
	Broken auger gearmotor	Replace the gearmotor.	TECHNICIAN
The flame turns off and the stove stops	Check that there are no "ACTIVE ALARMS" on the display	Service the stove.	TECHNICIAN
	Tank empty	Fill the tank.	USER
	Auger blocked by a foreign object (such as nails)	Clean auger.	TECHNICIAN
	Expired pellets	Try other types of pellets.	USER
	Pellet load value too low "PHASE 1"	Adjust the pellet load.	USER TECHNICIAN
The flames are weak and orange, the pellets don't burn properly and the glass turns black	Check that there are no "ACTIVE ALARMS" on the display	Service the stove.	TECHNICIAN
	Insufficient combustion air	Check the following items: any obstructions to the combustion air inlet from the back or under the stove; blocked holes in the burn pot grille and/or too much ash in the burn pot housing, Have the extractor blades and impeller cleaned.	TECHNICIAN
	Blocked exhaust	The flue is partially or totally blocked. Call a flue expert, who will examine the stove exhaust all the way up to the chimney stack. Have it immediately cleaned.	TECHNICIAN
	Clogged stove	Clean the inside of the stove.	USER

	Broken flue gas extractor	The pellets can also burn thanks to the vacuum in the flue, without the aid of the extractor. Have the flue gas extractor immediately replaced. It may be harmful to human health to operate the stove without the flue gas extractor.	TECHNICIAN
The exchanger fan continues to turn even if the stove has cooled	Defective flue gas temperature probe	Replace the flue gas probe.	TECHNICIAN
	Faulty electronic circuit board	Replace the circuit board.	TECHNICIAN
Ash around the stove	Faulty or broken door gaskets	Replace the gaskets.	TECHNICIAN
	Flue gas ducts not sealed	Consult a flue specialist, who will immediately seal the connectors with silicone for high temperatures and/or replace the pipes themselves with new ones that satisfy current regulations. Non-hermetic flue gas ducting may be harmful to human health.	TECHNICIAN
The stove is at maximum power but doesn't heat	Ambient temperature reached	The stove runs at minimum. Raise the desired ambient temperature.	USER
Stove at full power and the display shows "Over temperature flue gases"	Flue gas outlet limit temperature reached	The stove runs at minimum. The problem must be checked by a technician.	TECHNICIAN
The stove's flue gas ducting creates condensate	Low flue gas temperature	Check that the flue is not clogged.	USER
		Increase the reduced stove power (pellet feeding and fan rotation).	USER
		Install condensate collection trays.	TECHNICIAN

11. CLEANING

The cleaning operations can be performed by the user as long as all the instructions given in this manual have been read and understood.

It is recommended to carry out the cleaning operations with the stove off and cold.

Opening the door

To open the door, use the opening lever wearing a glove for high temperatures.

Cleaning the inside of the hearth

Daily or before each ignition, it is necessary to check that the burn pot is clean to ensure the free flow of combustion air from the holes of the burn pot itself.

Remove the ash that has accumulated inside the burn pot (fig. 1).

If necessary, remove the ash drawer and empty it out, taking care to remove any residues from the compartment that contains (fig. 1).

 Using an ash vacuum can simplify the cleaning operations.

Cleaning the flue compartment

The flue compartment must be cleaned every 2 months or whenever necessary.

After cleaning the burn pot, remove it and clean the compartment that contains it (fig. 2).

Remove the ash drawer and, using a special ash vacuum, remove any residues in the compartment that contains it.

 CAUTION: to clean the exchanger circuit and flue box, contact a qualified technical assistance centre.

Cleaning the flue gas circuit

Every 400 kg of pellets burnt, or once per season, the flue gas circuit needs to be cleaned of any residue (fig.3).

Cleaning the glass

It is carried out with a damp cloth or with dampened paper that is wiped over the ash (fig.4). Rub until the glass is clean.

Do not clean the glass while the stove is on and do not use abrasive sponges. The fire door glass should be cleaned every day.

Cleaning the flue gas ducting

Every 400 kg of pellets burnt, or once per season, the flue ducts need to be cleaned of any residue. Once per year, clean any soot using brushes.

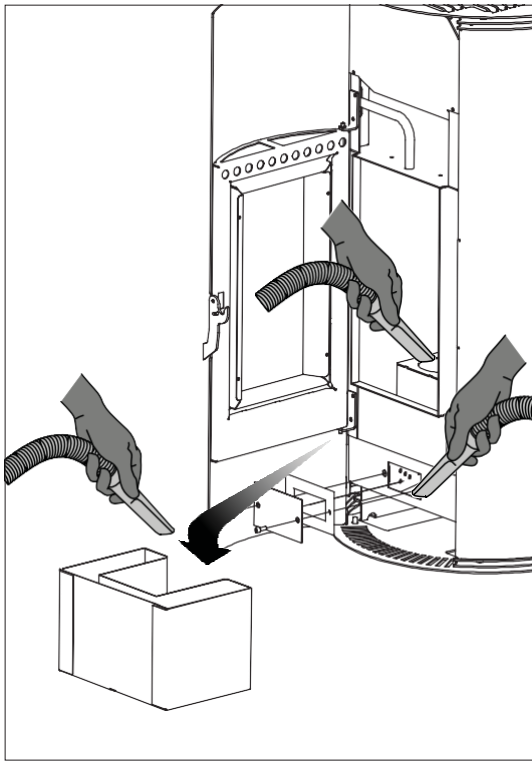

Figure. 1

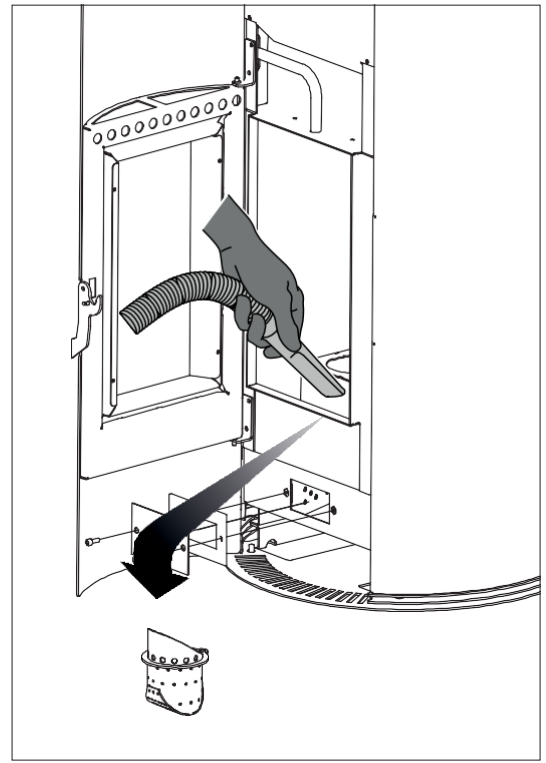

Figure. 2

OPTIMAL ASH DRAWER

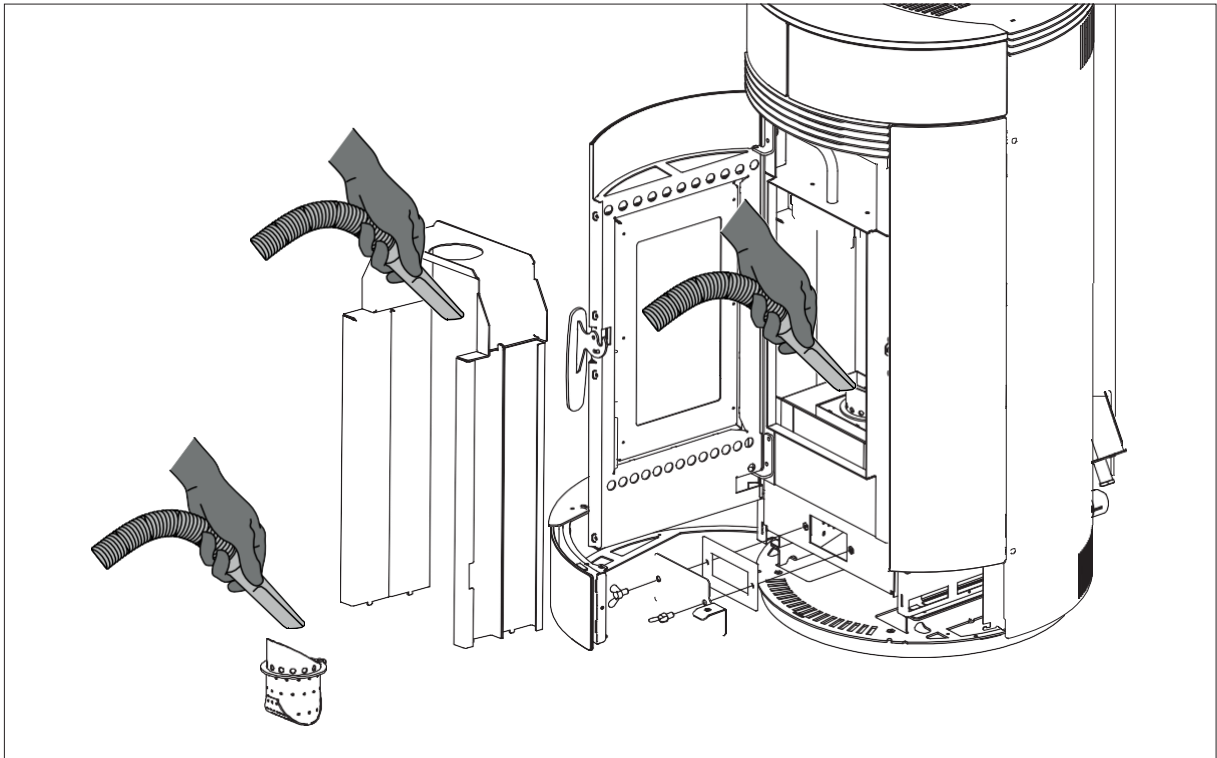



Figure. 3

The cleaning operation must be carried out by a flue specialist, who must clean the duct of any flue gases, the flue and the chimney stack, also checking their efficiency and issuing a written declaration confirming the safety of the system. This operation must be carried out at least once per year.

Cleaning the tank and auger

Each time the pellets are refilled, check for the presence of any dust/sawdust or other scraps on the bottom of the tank. If present, remove it with the help of a vacuum cleaner.

 The hand protection grille must never be removed from its housing. Clean the bottom of the tank and the visible part of the auger.

Cleaning the painted metal parts

Use a damp cloth to clean the painted metal parts. Never use degreasing substances such as alcohol, thinners, acetone, benzene, as these may irreparably damage the paint

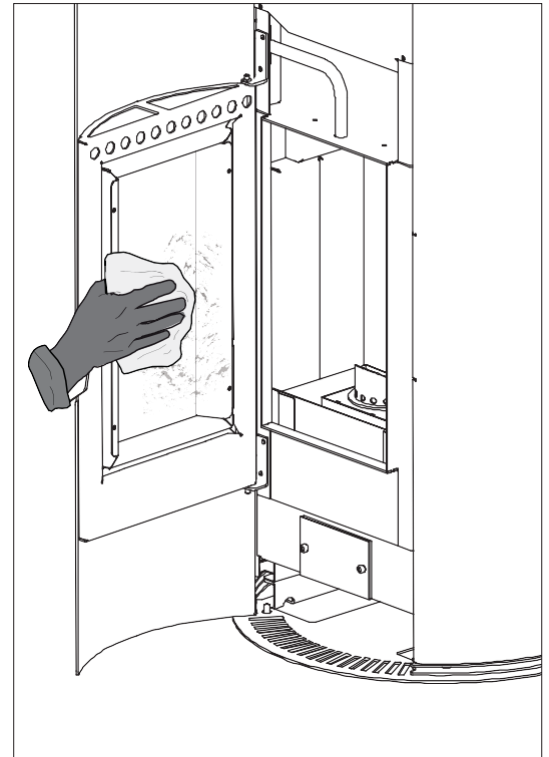

Figure 11.3

12. INFORMATION ON DISPOSAL (THROWING AWAY) AND DISMANTLING (PULLING APART) THE STOVE

Dismantling and throwing away, or disposing of an old used stove is the sole responsibility of the owner.

The owner of the stove must abide by the regulations in his/her country related to the safety and environment protection. Dismantling and disposing of the stove may be left to a third party to do if the third party is a company authorized to collect and dispose of such materials.

NOTICE: *In all cases you must abide by the applicable regulations of the country where the stove is installed regarding disposal of such materials (things) and, if necessary, report the disposal of such items.*

ATTENTION

Dismantling the stove must be done only when the chamber of the stove is not working and when the stove is unplugged from power (no power supply).

- *pull out all electric parts,*
- *throw away the battery and electronic cards in the proper garbage cans in accordance with the standards.*
- *separate the batteries you are keeping from the electric cards,*
- *dismantle the stove with the help from an authorized company*

ATTENTION

Disposing of the stove in public places poses a serious risk for people and animals. In such cases it is always the responsibility of the owner if a person or an animal gets hurt.

When the stove is dismantled, this manual and all other documents related to the stove must be destroyed.