



D.O.O. METAL INDUSTRY VRANJE
Radnička br. 1

PELLET STOVE

LUCA



LUCA R



**INSTRUCTION MANUAL FOR INSTALLATION, HANDLING AND MAINTENANCE OF THE
STOVE**

Pellet → wood biomass fuel → **biofuel**

The heating devices (in this instruction manual they are called „stoves“) from the company ALFA PLAM (in this instruction manual referred as ALFA PLAM) are designed and tested in accordance with the safety measures of the valid regulations of the European Community.

This instruction manual is intended for the stove users, the technicians who install the stove, the operators and workers for maintenance of the stove who are shown on the front (cover) page of the instruction manual.

If there is something in this instruction manual that is difficult for you to understand, we kindly ask you to contact the manufacturer of the stove or an authorized service center. In doing so, indicate the number of paragraph i.e. the chapter in question, i.e. the subject of something unclear.

Printing, translation and reproduction, even partial, of this instruction manual is subject of permit by ALFA PLAM, meaning that the company ALFA PLAM must approve the indicated actions. Technical information, figures and specifications in this instruction manual must not be given to any third entity.

DOUBLE COMBUSTION SYSTEM

The flame obtained by wood combustion in the stove, emits the same quantities of carbon dioxide (CO₂) which would be released as a result of natural wood decay.

The quantity of carbon dioxide (CO₂) obtained by combustion or decomposition of the biomass corresponds to the quantity of carbon dioxide (CO₂) that the biomass is able to receive from the environment and to turn it into oxygen for air and carbon of plants during its entire lifetime.

The use of non-renewable fossil fuels (coal, oil, gas), contrary to what happens with wood, releases in the atmosphere huge quantities of carbon dioxide (CO₂) which has been accumulated during millions of years, thus creating the effect of a greenhouse. For this reason, the use of wood as fuel is in perfect balance with the environment, because wood as a renewable fuel is in ecological harmony with the nature.

These goals are entirely achieved with principle of pure combustion, so for this reason the company ALFA PLAM has founded the design of its products on that basis.

What do we mean by clean combustion and how does it happen?

The regulation and setting of primary air and insertion of secondary air creates i.e. causes secondary combustion, or so called post-combustion, which gives secondary flame which according to its nature is lighter and stronger than the basic or primary flame. The addition of new oxygen (through inserted air) enables additional combustion of gases which have not burned entirely. This significantly increases the thermal performance and reduces harmful emission of carbon monoxide (CO), because the incomplete combustion is based on minimum. The following are the basic characteristics of the stove and the remaining products of the company ALFA PLAM.

0.0. TECHNICAL CHARACTERISTICS OF THE STOVE

No.	Parameter	Unit	Explanation	Luca , Luca R
1	P_{nom}	kW	the nominal heat output or a range of outputs (dependent on fuel types), rounded to the nearest one decimal place	8,4
2	P_{SHnom}	kW	the nominal space heat output or a range of outputs (dependent on fuel types), rounded to the nearest one decimal place	8,4
3	P_{Wnom}	kW	the nominal water output (if an integral boiler is fitted) or a range of outputs (dependent on fuel types), rounded to the nearest one decimal place	/
4	P_{part}	kW	the part load heat output or a range of outputs (dependent on fuel types) if specified, rounded to the nearest one decimal place	2,9
5	P_{SHpart}	kW	the part load space heat output or a range of outputs (dependent on fuel types) if specified, rounded to the nearest one decimal place	2,9
6	P_{Wpart}	kW	the part load water output (if an integral boiler is fitted) or a range of outputs (dependent on fuel types) if specified, rounded to the nearest one decimal place	/
7	P_{slow}	kW	the heat output at slow combustion or a range of outputs (dependent on fuel types) if specified, rounded to the nearest one decimal place	--
8	P_{SHslow}	kW	the space heat output at slow combustion or a range of outputs (dependent on fuel types) if specified, rounded to the nearest one decimal place	--
9	P_{Wslow}	kW	the water heat output at slow combustion (if an integral boiler is fitted) or a range of outputs (dependent on fuel types) if specified, rounded to the nearest one decimal place	--
10	P_{acc in}	kW	accumulator heat input, in kW or W for Kachelofen inset appliances only, rounded to the nearest one decimal place	--
11	T_{acc in}	°C	temperature at the separate heat exchanger inlet, for Kachelofen	--

			inset appliances only, rounded to the nearest integer	
12	ζ_{acc}	Pa	the flow resistance of the separate heat exchanger as used in the test, for Kachelofen inset appliances only, rounded to the nearest integer	--
13	η_{nom}	%	the appliance efficiency at nominal heat output, rounded to the nearest integer	91
14	η_{part}	%	the appliance efficiency at part load heat output, rounded to the nearest integer	93
15	η_S	%	the appliance seasonal space heating efficiency at nominal heat output, rounded to the nearest integer	81
16	EEI	-	the energy efficiency index, rounded to the nearest integer	122
17	CO_{nom} (13 % O ₂)	mg/Nm ³	CO emission at 13 % oxygen content at nominal heat output, rounded to the nearest integer	98
18	CO_{part} (13 % O ₂)	mg/Nm ³	CO emission at 13 % oxygen content at part load heat output if specified, rounded to the nearest integer	88
19	CO_{slow} (13 % O ₂)	mg/Nm ³	CO emission at 13 % oxygen content at heat output at slow combustion if specified, rounded to the nearest integer	--
20	NO_{xnom} (13 % O ₂)	mg/Nm ³	NO _x emission at 13 % oxygen content at nominal heat output, rounded to the nearest integer	60
21	NO_{xpart} (13 % O ₂)	mg/Nm ³	NO _x emission at 13 % oxygen content at part load heat output if specified, rounded to the nearest integer	78
22	NO_{xslow} (13 % O ₂)	mg/Nm ³	NO _x emission at 13 % oxygen content at heat output at slow combustion if specified, rounded to the nearest integer	--
23	OGC_{nom} (13 % O ₂)	mg/Nm ³	hydrocarbon emission at 13 % oxygen content at nominal heat output, rounded to the nearest integer	9
24	OGC_{part} (13 % O ₂)	mg/Nm ³	hydrocarbon emission at 13 % oxygen content at part load heat output if specified, rounded to the nearest integer	7
25	OGC_{slow} (13 % O ₂)	mg/Nm ³	hydrocarbon emission at 13 % oxygen content at heat output at slow combustion if specified, rounded to the nearest integer	--
26	PM_{nom} (13 % O ₂)	mg/Nm ³	particulate matter emission at 13 % oxygen content at nominal heat output, rounded to the nearest integer	14
27	PM_{part} (13 % O ₂)	mg/Nm ³	particulate matter emission at 13 % oxygen content at part load heat output if specified, rounded to the nearest integer	15
28	PM_{slow} (13 % O ₂)	mg/Nm ³	particulate matter emission at 13 % oxygen content at heat output at slow combustion if specified, rounded to the nearest integer	--
29	P_{nom}	Pa	minimum flue draught at nominal heat output, rounded to the nearest integer	12
30	P_{part}	Pa	minimum flue draught at part load heat output if specified, rounded to the nearest integer	12
31	P_{slow}	Pa	minimum flue draught at heat output at slow combustion if specified, rounded to the nearest integer	--
32	P_W	kPa (bar)	the permissible maximum water operating pressure, if applicable, to be given with 1 decimal	--
33	d_R	mm	the minimum distances from the rear to combustible material, rounded to the nearest integer	250
34	d_S	mm	the minimum distances from the sides to combustible material, rounded to the nearest integer	250
35	d_C	mm	the minimum distances from the top to combustible material in the ceiling, rounded to the nearest integer	>750
36	d_p	mm	the minimum distances from the front to combustible material, rounded to the nearest integer	1500
37	d_F	mm	the minimum distances from the front to combustible material in bottom front radiation area, rounded to the nearest integer	0
38	d_L	mm	the minimum distances from the front to combustible material in side front radiation area, rounded to the nearest integer	1500
39	d_B	mm	the minimum distances below the bottom (not regarding feet) to combustible material, rounded to the nearest integer	0
40	d_{non}	mm	the minimum distances to non-combustible walls, rounded to the nearest integer	--

41	s	mm	Protective insulation according to manufacture r's instructions	--
42	e/_{SB}	kW	the consumption of electrical auxiliary energy at standby, to be given with 3 decimals	0,004
43	e/_{max}	kW	the consumption of electrical auxiliary energy at nominal heat output, to be given with 3 decimals	0,074
44	e/_{min}	kW	the consumption of electrical auxiliary energy at part load heat output, to be given with 3 decimals	0,032
45	E, f	V, Hz	Power supply voltage, frequency, rounded to the nearest integer	230V, 50 Hz
46	W_{max}	W	Maximum electric power input, rounded to the nearest integer	--
47	T_{snom}	°C	the flue gas outlet temperature at nominal heat output, rounded to the nearest integer	141
48	T_{spart}	°C	the flue gas outlet temperature at part load heat output, rounded to the nearest integer (to be given for pellet operation only)	95
49	Tclass	-	Chimney designation according to the appropriate chimney standard	T 200 G
50	φ_{f,g nom}	g/s	the flue gas mass flow at nominal heat output, rounded to the nearest one decimal place	8,4
51	φ_{f,g part}	g/s	the flue gas mass flow at part load heat output rounded to the nearest one decimal place (to be given for pellet operation only)	4,0
52	V_h	m ³ /h	The standing air loss, if specified, rounded to the nearest one decimal place	--
53	CON or INT	-	whether the appliance is capable of continuous operation (CON), whether the appliance is capable of intermittent operation (INT)	INT
54	d_{out}	mm	the diameter of the flue gas outlet, rounded to the nearest integer	80
55	L, H, W	mm	the overall dimensions of the appliance (length, height, width), rounded to the nearest integer ^a	530x955x500
56	m	kg	Mass of the appliance, rounded to the nearest integer	110
57	m_{chim}	kg	the maximum load of a chimney the appliance may carry, to be rounded to the nearest integer	0
58		-	meaning "read and follow the user operating instructions"	

Table 1

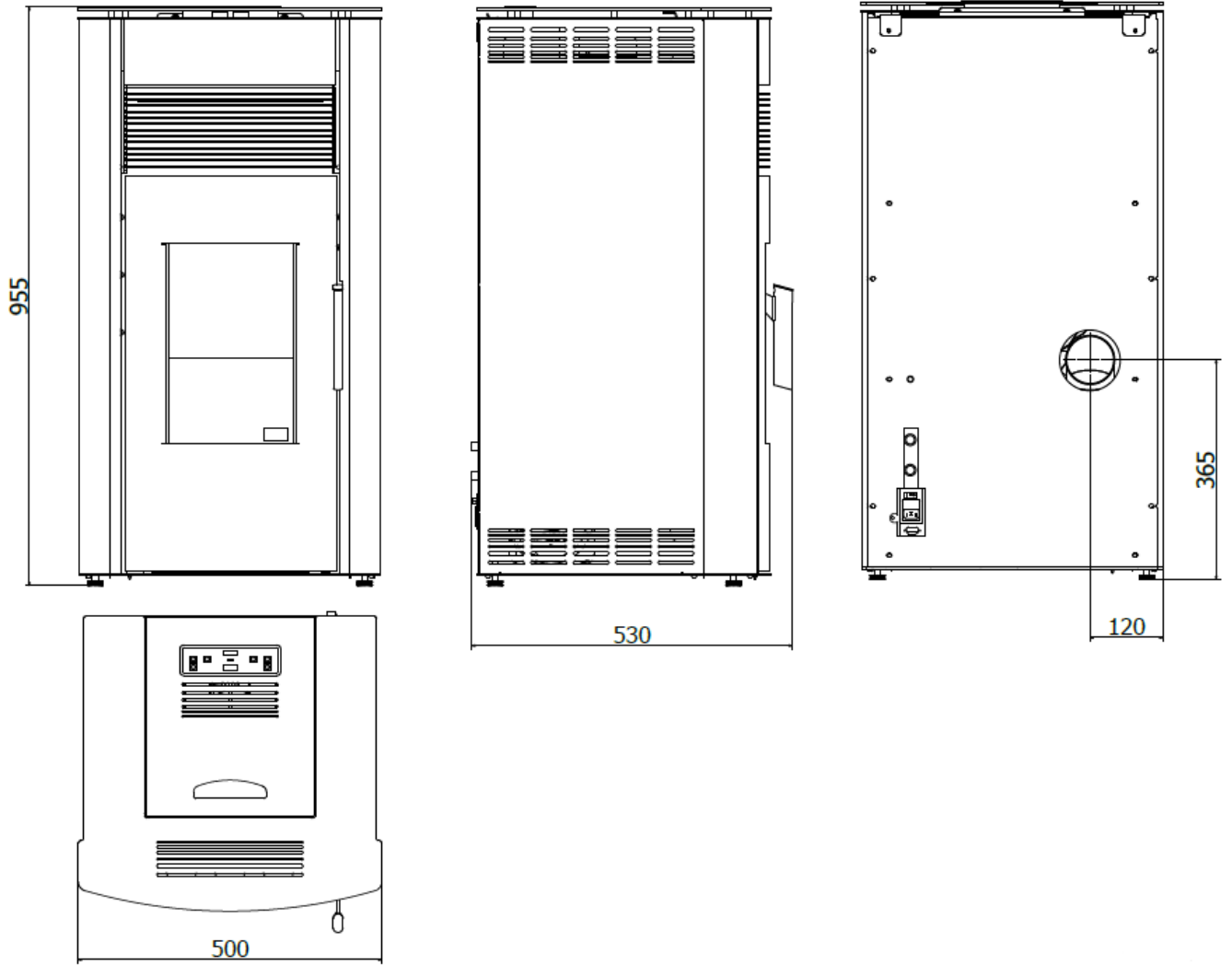

Figure 1 - Luca - Dimensions

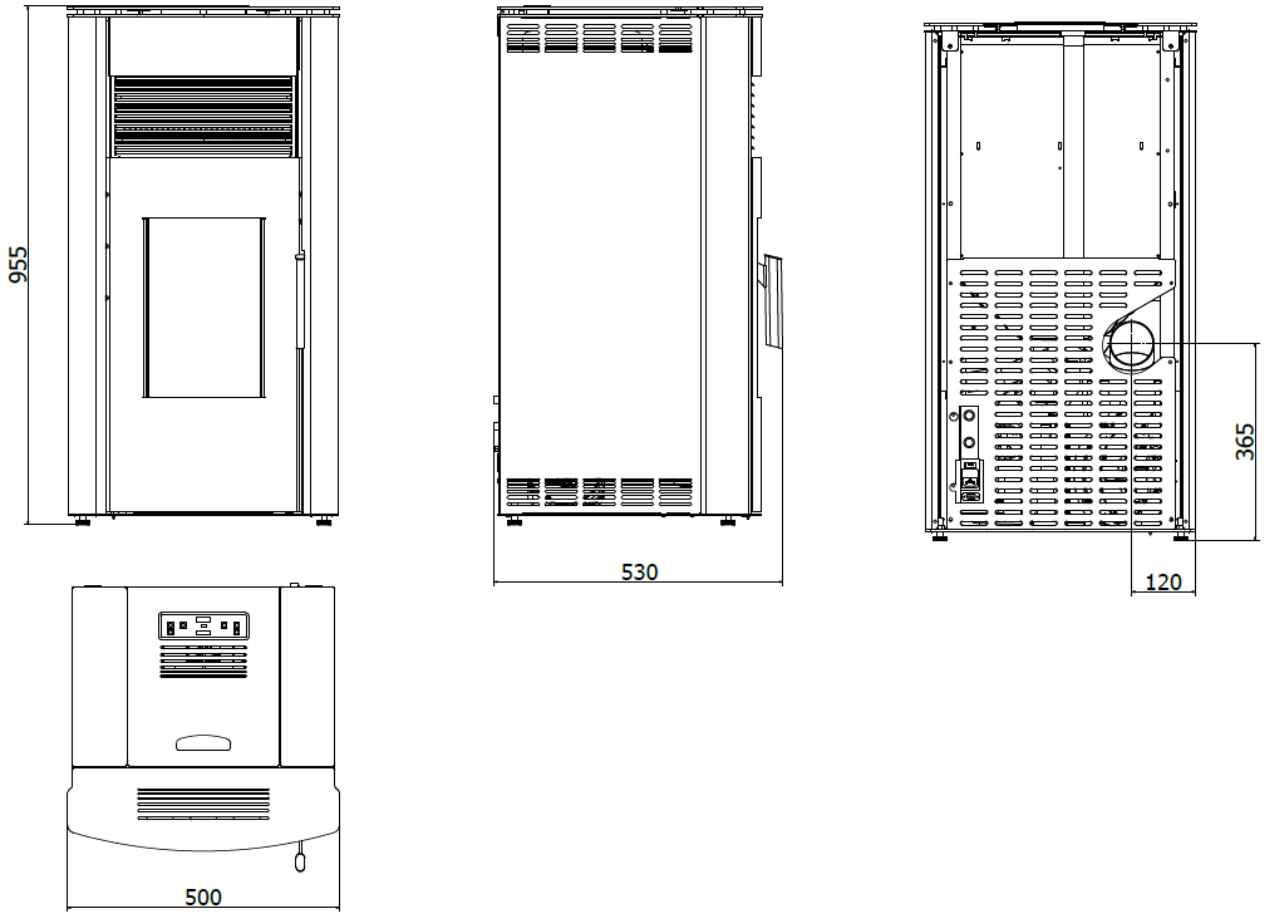

Figure 1a - Luca R - Dimensions

Contents:

1.	PURPOSE OF THIS INSTRUCTION MANUAL.....	1
1.1.	UPDATING	1
2.	RESPONSIBILITY OF THE MANUFACTURER.....	1
2.1.	BASIC CHARACTERISTICS OF THE USER	1
2.2.	TRANSPORTATION AND USE OF THE STOVE - HANDLING (MANIPULATION)	1
2.3.	RESPONSIBILITY OF THE INSTALLER.....	1
3.	CHARACTERISTICS OF FUEL	2
3.1.	CHARACTERISTICS OF FUEL	2
3.2.	STORAGE OF PELLETS.....	2
4.	HANDLING AND TRANSPORT	2
5.	MOUNTING - INSTALLATION OF THE STOVE.....	3
5.1.	PLACEMENT OF THE STOVE.....	3
5.2.	COMBUSTION AIR	5
5.3.	SMOKE EXHAUST SYSTEM.....	5
5.4.	INSULATION AND DIAMETER OF OPENINGS (holes) ON THE ROOF (or on the wall)	8
5.5.	SUCTION OF THE COMBUSTION AIR (figure 13).....	9
5.6.	CONNECTION TO THE POWER SUPPLY	11
5.7.	STOVE LEVELLING	11
6.	IMPORTANT INSTRUCTIONS.....	12
6.1.	OPTIMISATION OF COMBUSTION	13
6.2.	VENTILATION	13
7.	SAFETY WARNINGS FOR THE MAINTENANCE STAFF.....	13
7.1.	SAFETY WARNINGS FOR THE USER	14
8.	STANDARDS FOR SAFE IGNITION AND CLEANING OF THE STOVE	14
8.1.	ROUTINE CLEANING AND MAINTENANCE PERFORMED BY THE STOVE USER	15
8.2.	CLEANING AND MAINTENANCE (for workers who work on maintenance)	16
8.3.	SPECIAL MAINTENANCE	17
9.	IMPORTANT SAFETY MEASURES	17
10.	THE QUALITY OF PELLETS IS VERY IMPORTANT	18
10.1.	STORAGE OF PELLET FUEL.....	18
11.	DESCRIPTION AND FUNCTIONING OF THE ELECTRONIC CARD.....	18
11.1.	DESCRIPTION OF THE ELECTRONIC CARD (KEYBOARD) (figure 24).....	18
11.2.	FUNCTIONING OF THE ELECTRONIC CARD	18
11.3.	PARAMETERS USED BY THE STOVE USER	20
11.4.	ALARM MANAGEMENT	21
11.4.1.	Alarm dEP no (pressure alarm – alarm of the pressure switch)	22
11.4.2.	Alarm ALAr Sond (alarm of the probe for flue gases).....	22
11.4.3.	Alarm ALAr hot (alarm for excessive smoke temperature).....	22
11.4.4.	Alarm of the chamber:	22
11.4.5.	Alarm for overheating of the chamber or temperature of the snail distributor for pellet supply: ..	22
11.4.6.	Alarm for failed ignition.....	23
11.4.7.	Alarm for power outage.....	23
11.4.8.	Alarm ALAr Fan (alarm for discharge fan)	23
11.4.9.	„StoP FirE“ (it is not an alarm)	23
11.5.	OPERATION WITH AMBIENT PROBE ON STOVE.....	24
12.	INFORMATION REGARDING DISPOSAL (THROWING OUT) AND DISASSEMBLY (SEPARATION) OF THE STOVE	25

1. PURPOSE OF THIS INSTRUCTION MANUAL

The purpose of this manual is to enable the user to take over all necessary measures and prepare the entire equipment and material in order to enable safe and proper exploitation i.e. usage of the stove.

1.1. UPDATING

These instructions represent a real piece of art at the moment when they are launched at the market. For this reason the company ALFA PLAM does not take into consideration the stoves which are already in the market with the corresponding technical documentation and considers them as deficient or inappropriate after any type of modification, adaptation and application of new technologies to newly launched devices.

The contents of this instruction manual must be carefully read i.e. studied. You must strictly adhere to all instructions given in this instruction manual. All information that this manual contains are necessary for installation, use and maintenance of your stove.

For that purpose, this instruction manual must be carefully kept for the necessary instructions in case of some problems or obscurities.

In the stove is given or sold to some other person, the new owner must also be given this instruction manual.

If you have lost this manual, you may ask for a new one from the manufacturer.

2. RESPONSIBILITY OF THE MANUFACTURER

By issuing this instruction manual, the company ALFA PLAM **does not accept any civil or legal responsibility, directly and indirectly due to:**

- accidents that occurred due to failure to meet the standards and specifications given in this instruction manual,
- accidents that occurred due to improper handling or use of the stove by the user
- accidents that occurred due to modifications and repairs which have not been approved by the company ALFA PLAM,
- bad maintenance
- unpredictable situations
- accidents that occurred due to application of unoriginal or incompatible spare parts which are not intended for this model of stove.

The installer – technician assumes full responsibility for the installation.

2.1. BASIC CHARACTERISTICS OF THE USER

The user must have the following basic characteristics:

- he/she should be an adult and responsible person,
- he/she should have certain technical knowledge that is required for routing maintenance of the electrical and mechanical components of the stove.

CHILDREN MUST NOT COME NEAR TO THE STOVE, OR PLAY WITH IT WHILE IT'S WORKING.

2.2. TRANSPORTATION AND USE OF THE STOVE - HANDLING (MANIPULATION)

While the stove is used, you must make sure that the stove does not lean forward. This is because the center of gravity of the stove is positioned forwards.

During movement of the stove, which must be entirely safe, make sure that the forklift has carrying capacity which is bigger than the weight of the stove that it needs to lift. Avoid pulling and sudden moves.

ALL PACKAGING SHOULD BE REMOVED AND FAR FROM THE REACH OF CHILDREN SINCE THE MATERIAL WHICH IS PART OF THE PACKAGING MAY CAUSE SUFFOCATION. THIS INCLUDES PLASTIC BAGS, FOILS, POLYSTYRENE ETC.

2.3. RESPONSIBILITY OF THE INSTALLER

The responsibility of the installer is to execute all checks of the flue pipe, the air suction i.e. the air inlet, as well as all solutions required for mounting (installation) of your stove.

The responsibility of the installer is to coordinate the stove with the local legal regulations that apply in the place where the stove is mounted (installed).

The application of the stove must be in accordance with the instructions that are given in this instruction manual for use and maintenance as well as all safety standards that are given with the local legal regulations that apply in the place where the stove is mounted (installed).

The installer must **verify (confirm):**

- the type of stove which is installed,
- the appropriateness of the room where the stove is installed, which is expressed as a minimal value required for mounting, and which is stipulated by the stove manufacturer,
- the instructions of the thermal generator manufacturer that refer to the requirements of the smoke exhaust system (lines and pipes for smoke exhaust),
- the internal cross section of the flue, the material it is made of, the balance of the cross section, to make sure there are no barriers and obstacles in the flue.
- the height and vertical flue extension,
- the altitude of the place of mounting, that is, the place of installation of the stove,

- the existence and convenience of the protective cover of the flue resistant to wind activity,
- the possibility of providing suction of external air and the size of the required opening,
- the possibility for simultaneous use of the stove that should be mounted with the remaining equipment that already exists in that place.

If the results of all checks are positive, then mounting, that is, installation of the stove may follow. Make sure to adhere to the instructions which are given by the stove manufacturer, as well as the standards for fire-protection and the foreseen safety standards.

Once the installation is finished, the system must be put into trial operation for not less than 30 minutes in order to check all gaskets i.e. all system seals.

Once the installation and the important details are finished, the installer must provide the following to the clients:

- Instruction manual for use and maintenance issued by the stove manufacturer (if such instruction manual was not delivered with the stove),
- the documentation necessary for compliance with the existing standards.

3. CHARACTERISTICS OF FUEL

3.1. CHARACTERISTICS OF FUEL

The pellet (fig. 2) is composed of various types of wood, compressed using mechanical processes in accordance with environmental protection laws and is the only type of fuel intended for this type of stove.

The efficiency and thermal potential of the stove may vary depending on the type and quality of the pellets used.

We recommend the use of class A1 pellets (ISO 17225-2, ENplus A1, DIN Plus or NC 444 category "High Performance NF Pellets Biofuels Quality").

 The loading compartment is positioned in the upper part. It must always be openable in order to load the pellets and must remain closed during stove operation.

For reasons of operating temperature control traditional wood operation is not possible.



 It is forbidden to use the stove as a waste incinerator.



Figure 2

3.2. STORAGE OF PELLETS

 The pellets must be stored in a dry environment where the temperature is not too cold.

It is recommended to keep a few bags of pellets in the room where the stove is used, or in a nearby place provided the temperature and humidity are acceptable.

 Wet and/or cold pellets (5°C) reduce the thermal potential of the fuel resulting in the need for more cleaning maintenance of the burn pot (unburned material) and of the firebox.

Pay particular attention to the storage and handling of pellet bags. Their crushing and the formation of sawdust must be avoided.

If sawdust is introduced into the stove's tank, this could cause the pellet loading system to become blocked.

Keep the fuel at a safe distance from the stove.

The use of poor quality pellets can compromise the normal operation of the pellet stove and result in forfeiture of the warranty.

4. HANDLING AND TRANSPORT

The stove is delivered complete with all the parts provided.

Pay attention to the tendency to unbalance the stove.

The centre of gravity of the stove is moved towards the front.

Bear in mind the above also when moving the stove on the transportation support.

During lifting, avoid jerking or abrupt movements.

Make sure the forklift truck has a capacity greater than the weight of the stove to be lifted.

The full responsibility of the lifting of loads lies on the person handling the lifting equipment.

 Make sure that children do not play with the components of the packaging (e.g. films and polystyrene). Danger of suffocation!

5. MOUNTING - INSTALLATION OF THE STOVE

The user assumes full responsibility for works performed at the place of installation.

Before commissioning the stove, the installer must fulfill all legal safety standards, and particularly:

- to check whether the placement of the stove corresponds to the local, national and European regulations,
- to respond to the demands which are given in this document,
- to make sure that the placement of the flue pipe and air suction correspond to the type of installed stove,
- not to make i.e. not to establish electrical connections by using temporary and/or non-insulated electrical cables,
- to check the efficiency of the grounding of the electricity system,
- always to use personal protective equipment and all protection assets which are stipulated by the valid local regulations,
- **always to provide enough servicing space required for any type of maintenance and repair of the stove**

5.1. PLACEMENT OF THE STOVE

We advise you to unpack the stove one it arrives at its location where it will be installed.

The stove stands on plastic feet with cast bolts M10 (pieces 4) which are screwed into the stove base. On the bolts there are screws M10mm up to the plastic part. The feet are also screwed to the end, to the base of the stove. After unpacking the stove, once you bring it to the spot where it will be placed, it is necessary to unscrew all feet, so that the total height from the floor to the stove base is obtained, that is, the feet protrude from the stove base for about 25mm. After you finish the leveling of the stove which should stand horizontally with nuts that you screw with the wrench 17 and which should pass through the stove base, simultaneously tighten the nuts by holding the plastic part of the feet. The height of about 25mm from the floor to the stove base is necessary for air circulation and better cooling of the stove. In this manner you protect the stove from overheating and you are extending its lifetime.

If the adjacent (surrounding) wall and/or floor are made of material which **is not thermally resistant**, then you should use an appropriate protection whereby you will use a non-burning insulation material.

Always make sure to leave safe distance (about 35/40 cm) between the stove and the furniture, kitchen appliances etc. In order to protect the floor, if it is made of flammable material, we propose that you put a metal panel with a thickness of 3 to 4 mm on the floor under the stove, which will pass 30 cm in front of the front side of the stove.

The stove must be at a distance of at least 30 cm from the surrounding walls. Always leave at least 35 cm between the back part of the stove and the wall to enable proper circulation of air, that is, to enable proper air flow in that part.

If the stove is placed in a kitchen with a grate for air extraction or if it is placed in a room, that is, rooms with solid fuel thermal generators (such as wood stoves), always make sure that the amount of inlet air (in the kitchen or in the room) is sufficient to provide safe operation of the stove.

If the channel for smoke outlet should pass through the ceiling, it should be properly thermally insulated by using insulation from a non-burning insulation material. Once the stove is placed to its position, it should be leveled by using adjustable feet.

DANGER

The reinforcement of the smoke outlet **MUST NOT** be connected, that is, linked:

- to the flue pipe which is used by some other thermal generator (boilers, stove, fire-places, ovens etc.)
- to a system for air extraction (grates, ventilation openings etc.), even if the system is inserted in the flue outlet.

DANGER

It is forbidden to install shut-off valves for air flow (draft) (flaps, valves that can prevent air flow, that is, to disable draft).

ATTENTION

If the path of smoke exhaust such that it creates bad draft, that is, bad air flow (numerous curves, inappropriate smoke exhaust end, narrowing etc.), the smoke exhaustion can be bad i.e. in such cases the smoke exhaustion is not the best really.

The smoke exhaust system from the stove functions on the basis of negative pressure and slight pressure from the smoke outlet pipe. It is very important that the smoke outlet system is hermetically closed (sealed). This required application of a smooth pipe from the internal side. First of all, it is necessary to analyze and study the plan and the structure of the room well enough at the moment when the smoke outlet pipe is installed through walls and the roof, in order to execute the installation of the pipe properly in accordance with the standards for fire protection.

First it should be ensured that there is enough air for combustion in the room where the stove is located. It is recommendable to perform temporary inspection in order to ensure that the air for combustion comes properly to the chamber for combustion of biofuel. The stove functions on 230 V – 50 Hz. Pay attention not to tangle the power cable under the stove, to keep the cable far from warm spots and not to touch any sharp edge that could cut it. If the stove is electrically overloaded, this may lead to reduction of the lifetime of the electronic components of the stove.

Never switch off the power supply by pulling out the switch while there is flame in the stove. This may threaten the proper functioning of the stove.

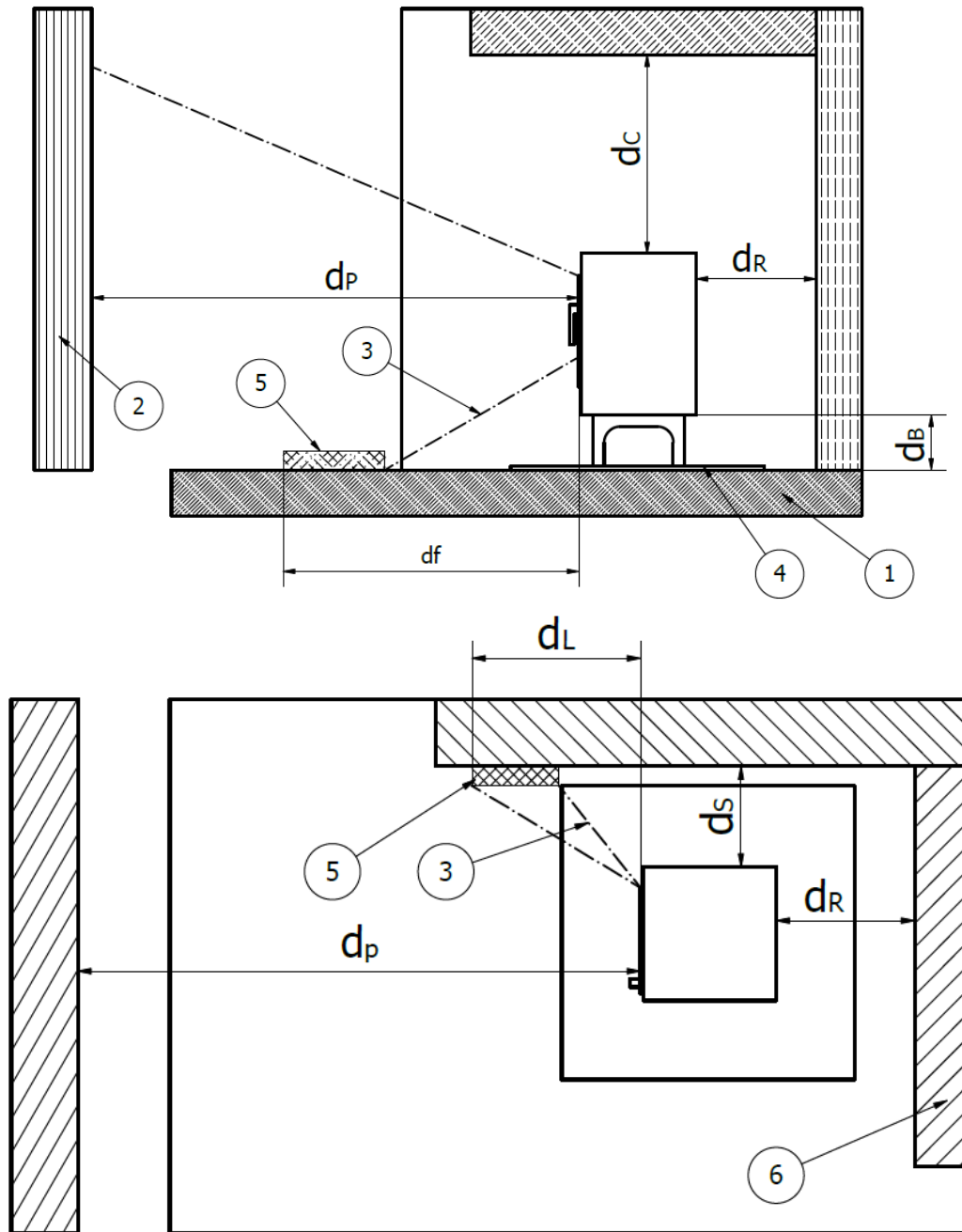

Figure 3 - All minimum safety clearances are listed on the technical nameplate, DO NOT use lower values than those specified (view CE MARKING INFORMATION).

Bottom (which is 0mm in case of appliances without feet)	d_B	0 mm
Floor in Front	d_F	0 mm
ceiling	d_C	750 mm
rear	d_R	250 mm
side	d_S	250 mm
Side radiation area	d_L	1500 mm
front	d_P	1500 mm

Table 2

1.	Trihedron floor
2.	Trihedron-like front plate
3.	Radiation area
4.	Floor protection plate
5.	Critical area (65K superseded due to radiation)
6.	Trihedron walls

Table 3

5.2. COMBUSTION AIR

! During use, the stove withdraws a certain quantity of air from the environment where it is located (except for products in the hermetic series, which can withdraw air directly from the outside); this air must be reintegrated through an external air intake (fig. 5-PA = Air Intake).

If the rear wall of the stove is an external wall, create a hole for suction of the combustion air at a height of approximately 20-30 cm from the ground, respecting the dimensional indications provided in the product technical sheet at the end of the manual.

A non-closable permanent aeration grid must be placed external; in areas that are particularly windy and exposed to weathering, provide rain and wind protection.

Make sure the air intake is positioned so that it is not accidentally obstructed.

If it is impossible to create the external air intake in the rear wall of the stove (non-perimeter wall) a hole must be created in an external wall of the room where the stove is positioned.

If it is not possible to create the external air intake in the room, an external hole can be created in an adjacent room provided it communicates permanently with a transit grille. (fig. 5.4 - C = Box, G = Grille, S = Shutter)

The UNI 10683 standard prohibits the taking of combustion air from garages, combustible material warehouses or activities with the risk of fire.

If there are other heating appliances in the room, the combustion air intakes must guarantee the necessary volume of air for correct operation of all the devices.

In the event that one or more extraction fans (suction hoods) are present and functioning in the room where the stove is located, combustion malfunctions due to the lack of combustion air could occur.

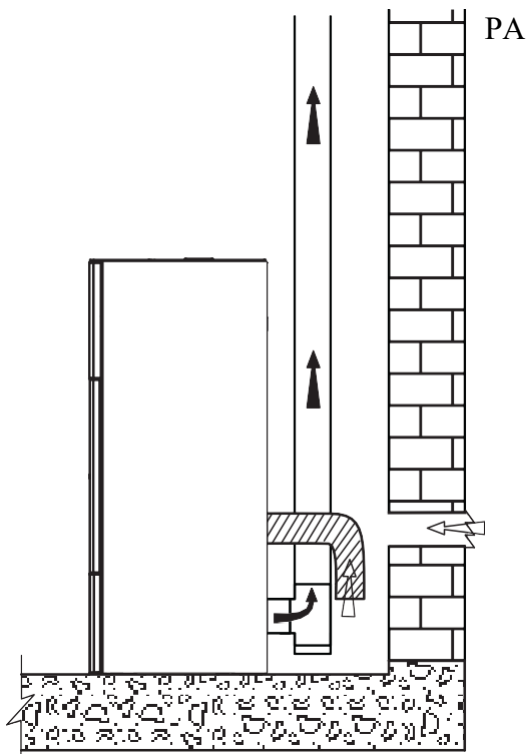

Figure 4

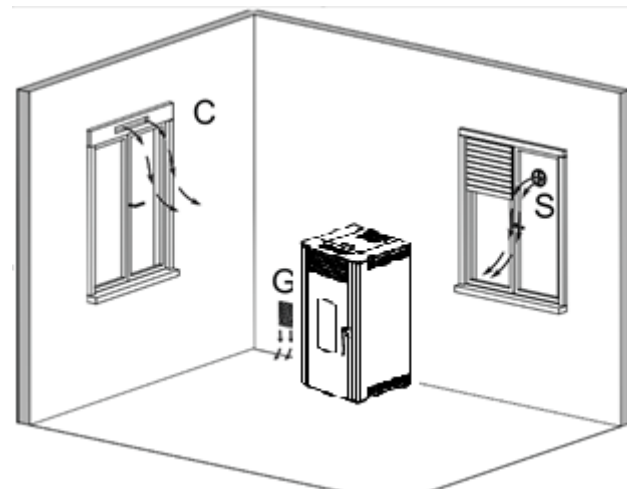

Figure 5

Product images are purely indicative.

5.3. SMOKE EXHAUST SYSTEM

The smoke exhaust must be executed in accordance with the existing standards. The exhaust pipe should be well sealed. Look figures 6 to 12.

Classical wall flues may be used for the smoke outlet and also flues can be made of pipes which must be well insulated (double wall) and sealed to avoid creating of condensation inside them.

The exhaust pipe absolutely must not be connected to the remaining systems of any type, such as systems where the smoke is exhausted from the combustion chamber, the exhaust rail or the air distribution system etc. Also the flue exhaust must not be placed in closed or semi-closed rooms such as garages, tight corridors, under closed barracks or in any other place where smoke could appear. Once the stove is connected to the smoke exhaust pipeline, it is necessary to bring a professional chimney sweep to check and make sure that the flue doesn't have any small holes or cracks. If such cracks do exist in the flue exhaust, in such case the smoke exhaust pipe must be coated with new material for the purpose of proper functioning.

For this purpose, one may use rough pipes made of colored steel (with a thickness of minimally 1,5mm) or from stainless steel (with a thickness of minimally 0,5mm).

The smoke (flue) exhaust system from metal pipes must have grounding in accordance with the existing standards and legal regulations. **The grounding is demanded by law.**

This grounding connection must be independent from the stove grounding.

The smoke exhaust pipe must be made according to the standards in terms of dimensions and materials which are used for its construction (figure 6).

- A) Flue top resistant to wind
- B) Maximal cross section 15 x 15 cm or a diameter of 15 cm, maximal height of 4-5 m.
- C) Seal
- D) Inspection – control opening

Flue pipes that are in bad condition or that have been made of inappropriate material (asbestos cement, zinc coated sheet metal etc.) with rough or porous surface are illegal and they endanger the proper operation of the stove. The smoke can be exhausted through a classical flue pipe (see the following figures) provided that the following regulations are fulfilled:

- check the condition of maintenance of the smoke exhaust pipe or flue. If the smoke exhaust pipe is old, it should be replaced with a new one. If the flue has been damaged, it is good to repair the same or to renew it by inserting one steel pipe which is properly insulated with glass wool.

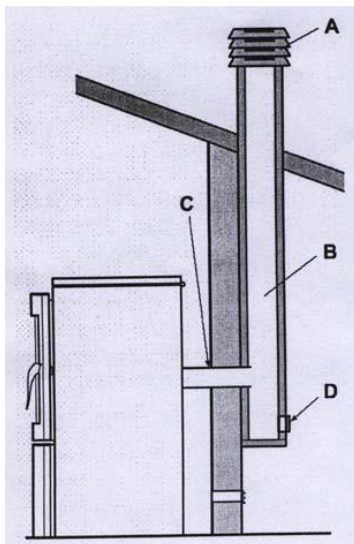

Figure 6

- the smoke can be directly headed in the smoke pipe (flue) only if it has a cross section up to 15x15cm or a diameter up to 15 cm and if it has a cover for check and cleaning.

- **If the flue has bigger cross section** than 15x15cm or a diameter bigger than 15cm, you can perform eventual regulation of increased draft (reduction) in the flue in three manners:

1. If the flue bottom has an opening for cleaning, it should be partially open.
2. Insert a steel pipe in the flue, with a diameter of 10cm if you own elements for such correction of the flue.
3. By regulation of certain parameters in the stove. This regulation may be performed only by an authorized service of Alfa Plam.

- Make sure that the connection to the house flue is properly sealed.

- Avoid contact with an easily burning material (such as wooden beams) and in all cases it is necessary to insulate them with fireproof material (see figure 7).

- A) Mineral wool
- B) Steel pipe
- C) Partition panel.

The stove is made for connection to a flue with a flue pipe with a diameter of 80mm. If the standard flue is not used, but a new flue is made, or if you are changing the existing one, use insulated stainless pipe (double wall) with a diameter according to the given table 4. Flexible pipes are not allowed.

TYPE OS SYSTEM	DIAMETER mm	SYSTEM ASSESSMENT
Pipe with a length of less than 5 m	80	Acceptable
Pipe with a length of more than 5 m	100	Compulsory
Installation in places above 1.200 masl	100	Recommendable

Table 4

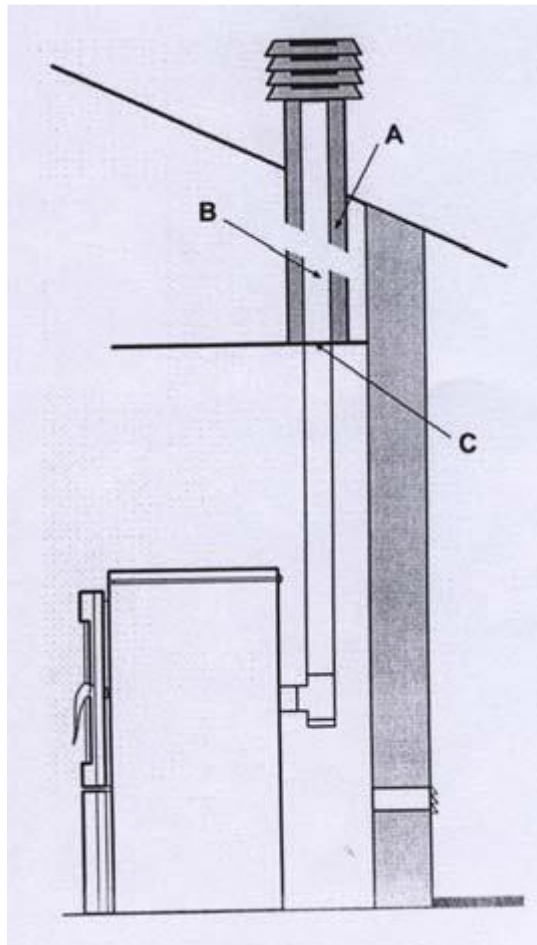

Figure 7

When you are using an external pipe between the stove and the smoke exhaust pipe, it is compulsory that you use one „T“ connection (joint) (as shown in figures 10 and 11), with a cover for cleaning (plug) by the stove. The application of these “T” connective reinforcements must enable collection of ash which is created inside the pipe and temporary cleaning of the smoke exhaust pipe without any need for pipe removal. The smoke is exposed to slight pressure. For this reason it is compulsory to check whether the opening, i.e. the cover (the plug) for cleaning of the smoke exhaust system is perfectly hermetically closed and that it remains like that after every cleaning. Make sure that the assembly is made in the same order and check the condition of the seals.

Perform the installation of the smoke pipes according to figure 12.

It is strictly recommendable to avoid use of horizontal extensions i.e. continuations, and if required, make sure that the pipe is not counter-inclined, but it has one slope of at least 5%. The horizontal extension can in no event pass the length of 3m.

It is not recommendable to connect the smoke exhaust directly to the stove with a horizontal extension longer than 1m. Look at figures 9,10,11 and 13. After the T joint, it is necessary that you place a vertical extension of \varnothing 80mm, length of at least 1-1,5 m and then after this to continue with the horizontal extensions of \varnothing 80mm and vertical extension of \varnothing 80 and \varnothing 100mm depending on the height of the smoke pipe (flue) as shown in table 4.

Figure 8 on the left side shows how the end (the top) of the flue should look like when you have two flues one by the other, and figure 8 on the right side shows what is not appropriate for making the end.

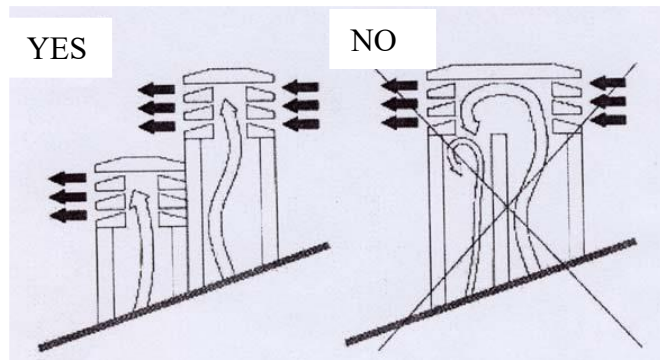

Figure 8

5.4. INSULATION AND DIAMETER OF OPENINGS (holes) ON THE ROOF (or on the wall)

Once the position of the stove is determined, it is necessary to make one hole i.e. an opening through which the smoke exhaust pipe should pass. This varies depending on the type of installation, the diameter of the smoke exhaust pipe (look at table 4) and the type of wall or roof through which the pipe should pass. Look at table 5. The insulation must be made of mineral wool with a nominal density bigger than 80 kg/m^2 .

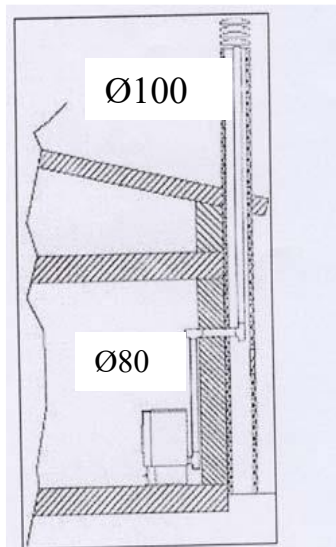

Figure 9

1. Reinforcement $80 > 100$
2. Pipe reinforcement with a "T" shape

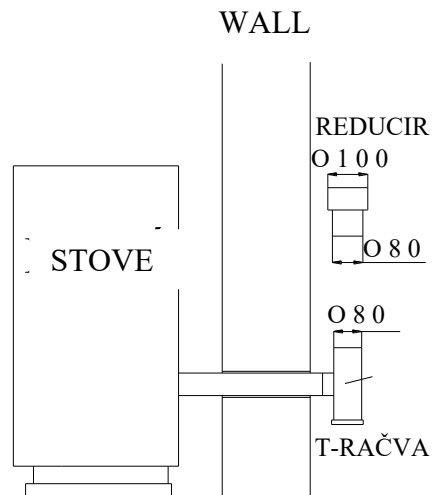

Figure 10

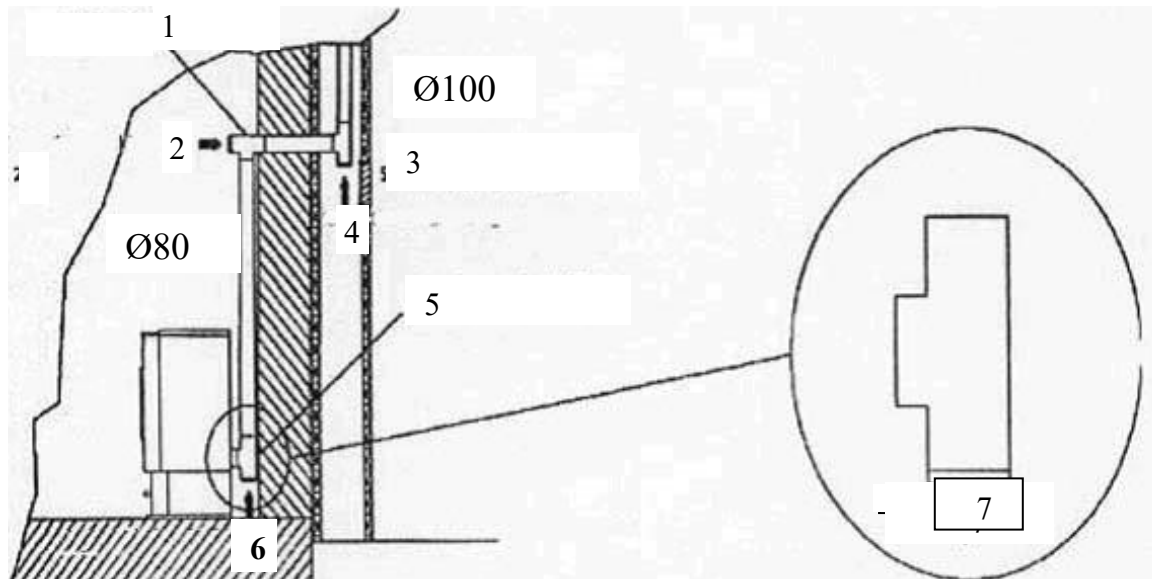

Figure 11

1. Pipe reinforcement with a "T" shape – T connecting joint
2. Direction of cleaning
3. Opening, window for servicing/inspection
4. Direction of cleaning
5. Pipe reinforcement with a "T" shape – T connecting joint
6. Direction of cleaning
7. Hermetical cover for cleaning (plug)

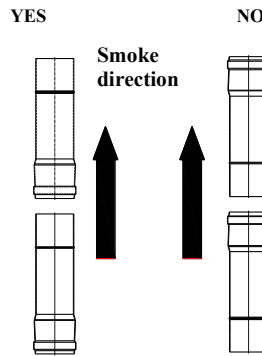

Figure 12. Manner of installation of the flue pipe

Thickness of the insulation mm		Diameter of the smoke exhaust pipe (mm)	
		D.80	D.100
		Diameters of holes (openings) which should be made (mm)	
Walls made of wood, or in any case flammable, or parts that are flammable	100	150	170
Concrete wall or roof	50	100	120
Wall or roof of bricks	30	100	120

Table 5: Thickness of insulation for part of a system which passes through a wall or a roof

Above all, it is necessary to enable PERFECT AIRFLOW (draft) in the smoke exhaust pipe which must be free with no obstacles such as different narrowings or corners. All displacements of the axis must have one path tilted with a maximal angle of 45 degrees from the vertical, and 30 degrees is the best solution. The best would be to make this displacement close to the flue top which is resistant to wind activity.

According to the **regulations (flue top resistant to wind, distances and placement of the stove)** the distances shown in table 6 must be fulfilled:

Roof slope	Distance between the ridge cover and the flue	Minimal height of the flue measured on the upper opening (at the exit from the flue)
α	Distance in meters	Height in meters
15°	Less than 1.85 m More than 1.85 m	0.50 above the ridge cover 1.00 meter from the roof slope
30°	Less than 1.50 m More than 1.50 m	0.50 above the ridge cover 1.30 meters from the roof slope
45°	Less than 1.30 m More than 1.30 m	0.50 above the ridge cover 2.00 meters from the roof slope
60°	Less than 1.20 m More than 1.20 m	0.50 above the ridge cover 2.60 meters from the roof slope

Table 6

However, it is compulsory to provide one initial vertical extension (continuation) of 1,5 meters (minimum) in order to provide proper exhaust i.e. extraction of the smoke.

5.5. SUCTION OF THE COMBUSTION AIR (figure 13)

The air required for combustion, which is taken from the environment, must be regenerated by means of one ventilation grate positioned on the room wall, that is, the room directed towards outside. This will enable better combustion, thus less consumption of pellet biofuel. It is not recommendable to intake the external air directly through the pipe, because this will reduce the efficiency, that is, the performance of the combustion. The ventilation opening must compulsorily be equipped at the external side with one ventilation grate such as protection from rain, wind and insects.

This opening must be made at the external wall of the room, that is, the room where the stove is located.

Intake, that is, supply of air for combustion from the garage, the depository for burning materials or from the room where there is risk of fire is forbidden.

The hole, that is, the opening of the external suction air for combustion must not be connected by means of pipe. If the room has some other equipment for heating, the suction for air for combustion must provide the amount of air which is necessary for proper operation of all devices.

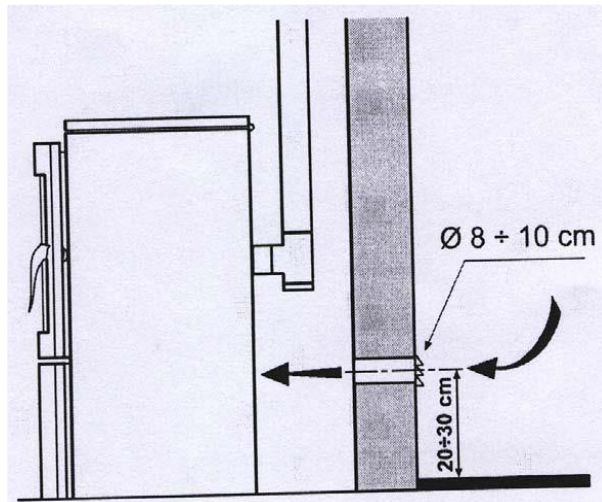
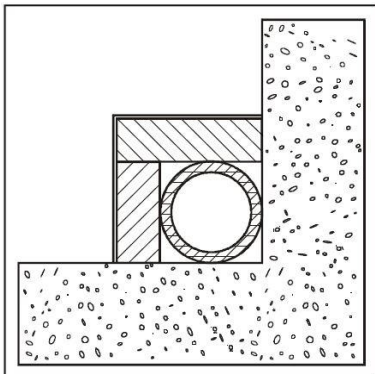

Figure 13 -MINIMAL DISTANCES FOR PLACEMENT OF THE VENTILATION GRATE:

For proper and safe placement of the ventilation grate look at the data given in table 7. These are minimal distances from every air space or smoke exhaust. This value can change the configuration of air pressure. It should correspond to the sequence in order to enable, for example, the open window to intake external air, taking it from the stove itself.

The ventilation grate must be placed at least		
1 m	Under	door, window, smoke exhaust, air chamber etc.
1 m	Horizontal from	
0.3 m	Above	
2 m	From	smoke outlet

Table 7: Minimal distances for intake of air for combustion



AISI 316 steel chimney with double insulated chamber, made of material resistant to 200°C. Optimal efficiency 100%

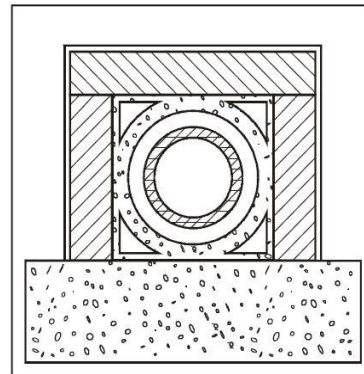

Fireproof chimney with double insulated chamber and an outer lining of lightweight concrete. Optimal efficiency 100%

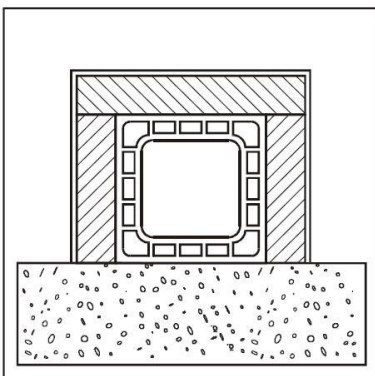

Traditional clay chimney with recesses. Optimal efficiency 80%

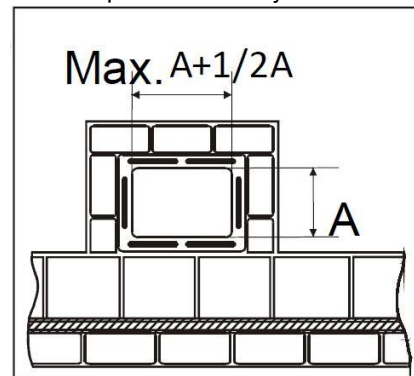

It is forbidden to use chimney pipes that have a rectangular internal cross-section with a ratio that differs from the plan. Modest efficiency 40%

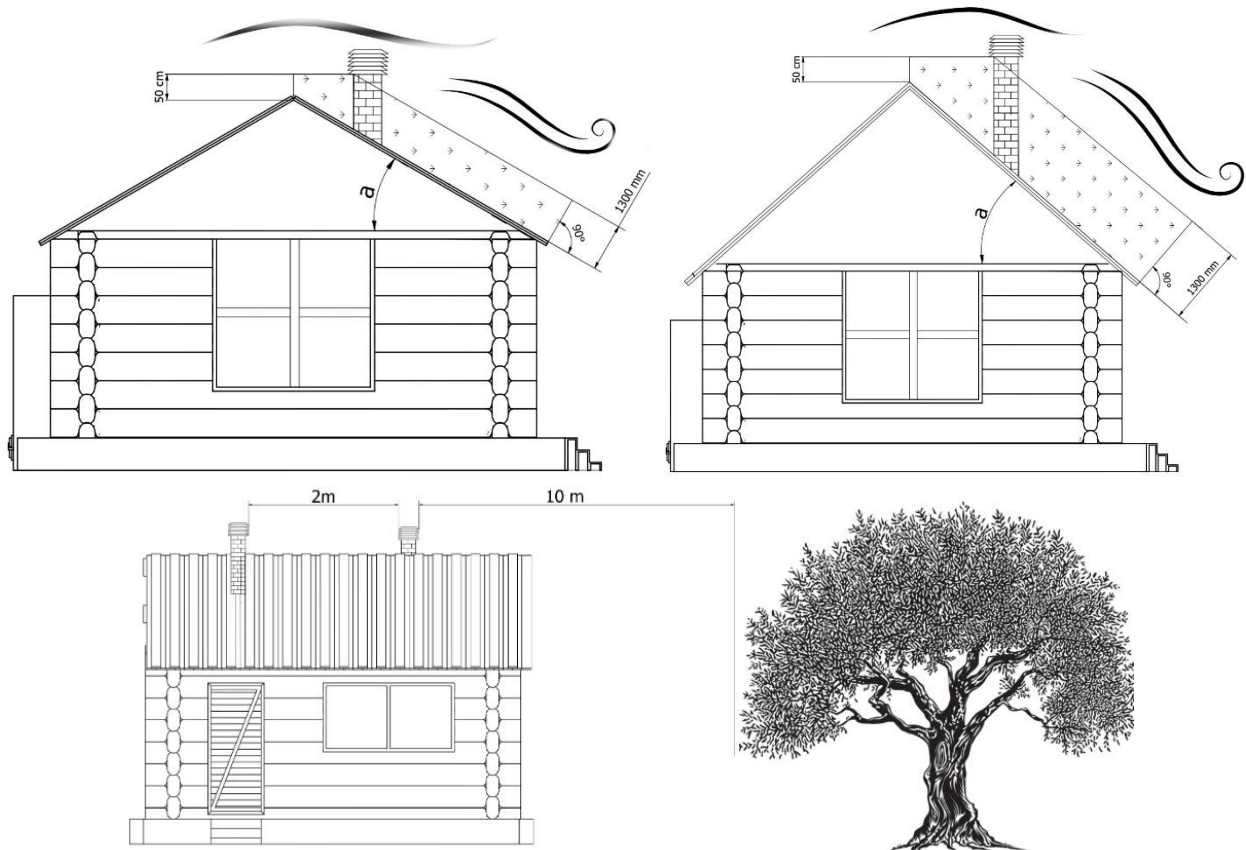

Figure 14 - Chimney - positioning and distance

5.6. CONNECTION TO THE POWER SUPPLY

This stove should be connected to power supply. Our stoves have electrical cables which are appropriate for middle temperatures. If required, replace the electrical cables (for example if it is damaged), then consult with our authorized technical staff, with our experts. Prior to connect the stove to the power supply, make sure that:

- the characteristics of the electricity system correspond to the data i.e. the specification which is given on the identification plate on the stove.
- The system for smoke exhaust, if it is metal, it must have a working connection for grounding in accordance with the existing standards and legal regulations. **The grounding is a legal regulation.**
- The electrical cable at no point may reach a temperature which is 80°C above the ambient temperature. If you want to directly connect the stove to power supply, then you should place one bipolar switch for minimal clearance between the contacts of 3mm, the dimensions for electrical load shown on the identification plate and in accordance with the existing standards. Yellow-green cable grounding must not be stopped with a switch. When the stove is installed, that is, placed at its position, the bipolar switch or socket must be easily accessible.
- If the stove is not going to be used for a longer period, switch off the stove from the power supply or put the switch into switched off (0) position. In case of defect or malfunctioning, immediately switch off the stove or put the switch into switched off (0) position and contact an authorized service center.

5.7. STOVE LEVELLING

The stove must be levelled, with the help of a spirit level, by regulating the adjustable feet (if included) fig. 15).

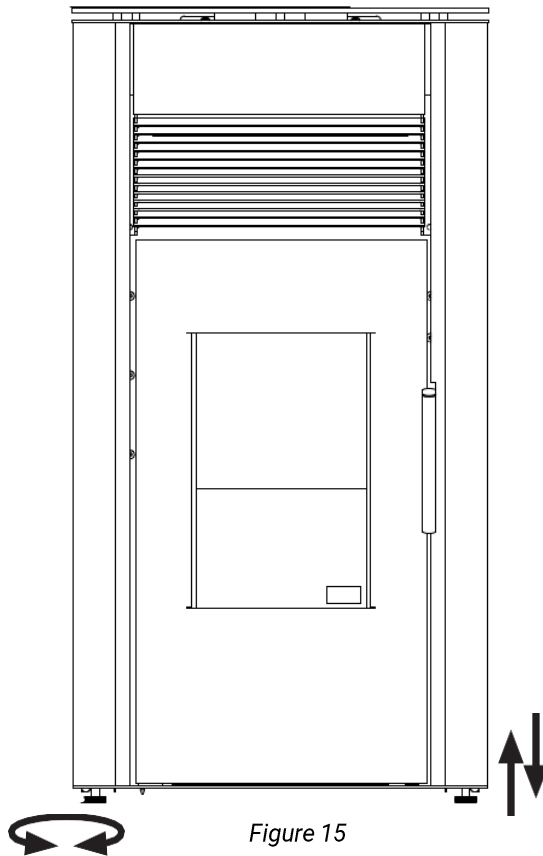

Figure 15

6. IMPORTANT INSTRUCTIONS

THIS IS AN IMPORTANT COMPULSORY INSTRUCTION MANUAL FOR THE SAFETY OF PEOPLE, ANIMALS AND PROPERTY.

We would like to inform the installer of the stove about some general instructions that he must adhere to, for proper installation i.e. for the purpose of proper mounting of the stove. These standards are required, but not entirely. For further and more precise information, it is required that you read the rest of this instruction manual.

- Connect the stove to the socket with grounding. Figure 16
- Put the switch on the back side of the stove to position 1. Figure 17
- Do not let children or house pets come near the stove.
- Use only pellet fuel, and not some other fuel type.
- Inform all users about the possible risks and dangers and learn them how to operate with the device.
- If the stove has been placed on wooden floor, then it is recommendable to insulate the base where it stands.

The stove functions with a chamber for combustion which is in negative pressure. **For this reason make sure that the smoke exhaust is thermally sealed, that is, insulated.**

When the stove switches on for the first time, then, due to stabilization of the painting process, a small quantity of the paint evaporates (it is not harmful to your health) which covers the stove. For this reason it is necessary to ventilate the room in order to remove the evaporation from the room.

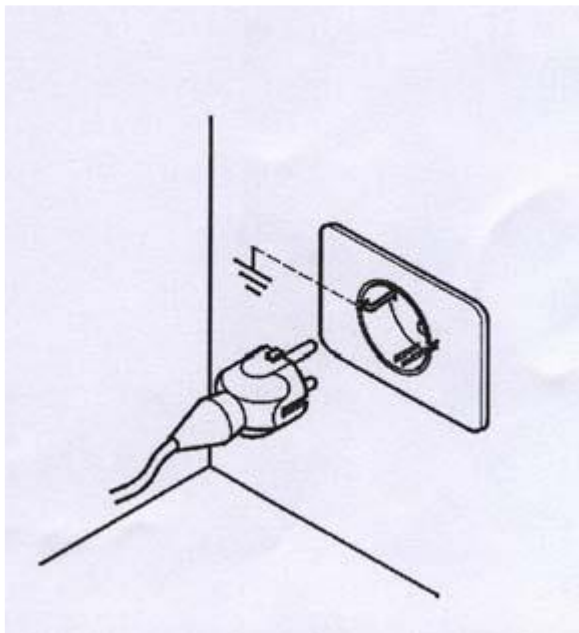

Figure 16

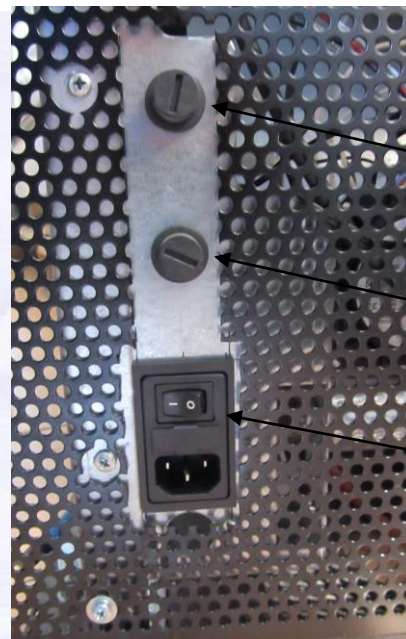

Figure 17

6.1. OPTIMISATION OF COMBUSTION

Best combustion depends on a variety of factors (type of installation, operating and maintenance conditions, type of pellets, etc...)

Upon the first ignition, the stove's combustion can be optimised.

Generally speaking, if there is a lot of residue in the burn pot at the end of combustion, it is recommended to adjust the combustion configuration (increasing the value) until the most suitable solution is found.

See sections 9.17- 9.18 - 9.19.

6.2. VENTILATION

The stove is equipped with ventilation.

The air pushed by the fans keeps the appliance at a low enough temperature, thus avoiding excessive stress on the materials of which it is composed.

Do not close the hot air outlet vents with any objects or the stove will overheat!

The stove is not suitable for cooking food.

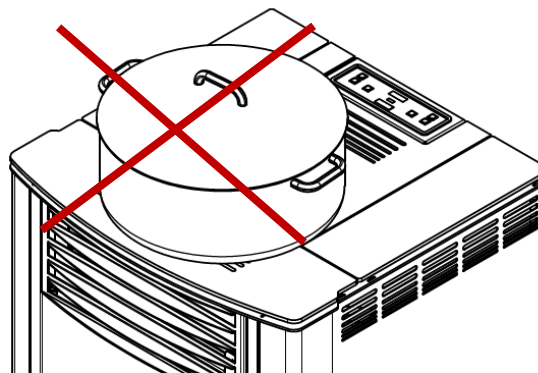

Figure 18

⚠ ATTENTION: Do not cover the air vents.

7. SAFETY WARNINGS FOR THE MAINTENANCE STAFF

The technicians who work on the maintenance, besides having to adhere to all security measures, they also must:

- always use safety devices and personal protective assets.
- switch off the power supply before the start working.
- always use an appropriate tool
- before they start any types of work on the stove, to make sure that the stove is cold and that the ash is cold as well. They should especially make sure that the handles are cold, before touching them.

- **NEVER ACTIVATE THE STOVE DURING OPERATION** if only one of the safety devices is defective, improperly set or nonfunctional.
- Do not make any modifications of any type for any reason except for the ones which are allowed and explained by the manufacturer.
- Always use original spare parts. Never wait for the components to become worn before replacing them. The replacement of a worn part i.e. component of the stove before it stops working, contributes for the prevention of injuries caused by an accident due to sudden failure i.e. defect of the component, and this may cause serious injuries to people and damages to property which is situated around the stove.
- Clean the firebox before igniting the stove.
- Make sure that there is no condensation. If condensation occurs, this is an indicator that water appesred from the cooling of the smoke. We recommend that you detect the possible causes so that you can establish normal and proper operation of the stove.

7.1. SAFETY WARNINGS FOR THE USER

The place where the stove is placed, called the place of mounting, must be prepared in accordance with the local, national and European regulations.

The stove is a „heating device“ and **during its operation it has surfaces which are very hot, that is, which have extremely high temperatures**, or which are quite hot.

This stove is made so that it burn fuel from pressed wood mass (pellets with a diameter from 6 mm to 7 mm, length from about 30 mm, maximal humidity of 8-9%).

For this reason, during its use, it is very important that you pay attention, especially to the following:

- do not come near or touch the door glass. DANGER OF GETTING BURNS exists
- do not come near or touch the smoke exhaust pipe. DANGER OF GETTING BURNS exists
- do not perform any cleaning
- do not open the door since the stove works properly only when it is hermetically closed
- do not dispose ash when the stove is in operational mode
- children and house pets must stay away from the stove
- ADHERE TO ALL REGULATIONS GIVEN IN THIS DOCUMENT – INSTRUCTION MANUAL

Also, for proper use of the pellet biofuel:

- use only fuel that corresponds to the instructions of the manufacturer,
- always adhere to the plan for maintenance of the stove,
- clean the stove every day (only when the stove and the ash are both cold),
- do not use the stove in a case of some malfunctioning or abnormalities, in case of unusual noise and/or suspicious defects,
- **do not throw or pour water on the stove, even for fire extinguishing,**
- **do not switch off the stove by pulling out the switch. Use a button for switching off boards,**
- do not tilt the stove, IT MAY BECOME UNSTABLE
- do not use the stove as a support or a bracket. Never leave the cover of the fuel tank open.
- do not touch painted parts while the stove is working,
- do not use wood or coal as fuel, **use only pellet as fuel** with the following characteristics: dimensions: diameter 6-7mm, maximal length of 30mm, maximal content of moisture 8-9%
- do not use the stove as a stove for burning waste,
- always perform all operations with maximal safety measures.

8. STANDARDS FOR SAFE IGNITION AND CLEANING OF THE STOVE

- Never ignite the stove with gasoline, petroleum or any other flammable liquid. Keep these types of liquids away from the stove while it works,
- Never burn the stove if the glass is damaged. Never hit the glass or the door to prevent their damaging,
- Do not open the door in order to clean the glass while the stove works. Clean the glass only when the stove is cold, by using a cotton cloth and paper towels and an asset for cleaning glass,
- Make sure that the stove is well tightened in order to prevent any movement,
- Make sure that the ash box is inserted and that it is completely closed, so that the doors have properly laid on the internal box,
- Make sure that the stove door is well closed while the stove is working,
- Extract the ash from the stove only when the stove is completely cold,
- Never use abrasive cleaning assets for the surfaces of the stove.

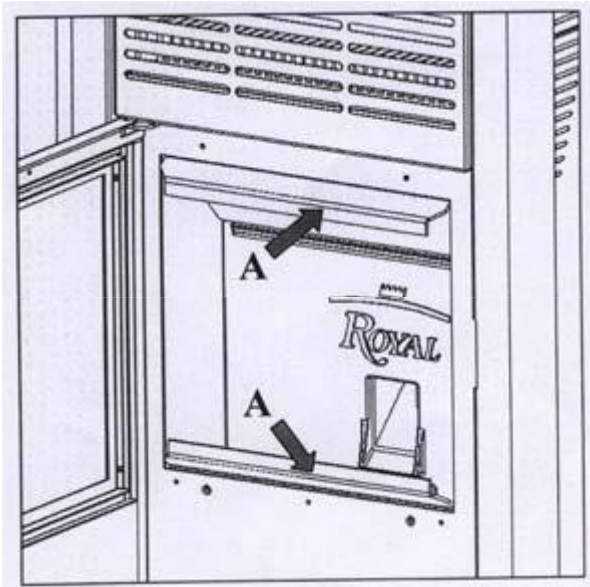

Figure 19

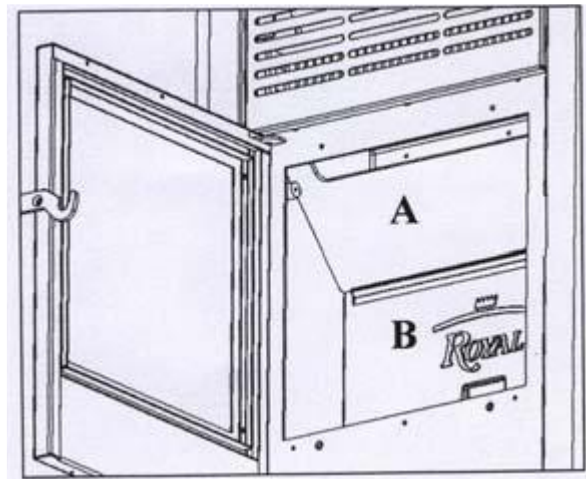

Figure 20

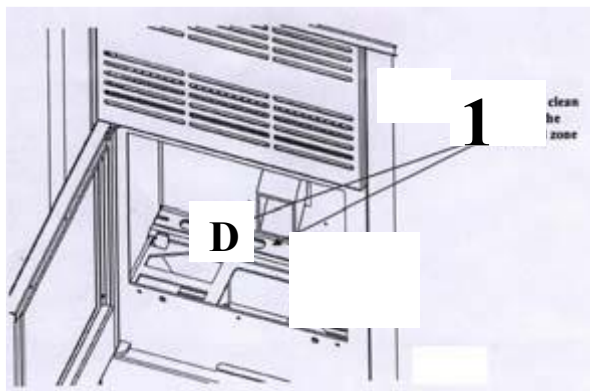

Figure 21

8.1. ROUTINE CLEANING AND MAINTENANCE PERFORMED BY THE STOVE USER

The use of a vacuum cleaner with a shell and tube shape can facilitate the cleaning of the stove. The vacuum cleaner must have a filter which prevents the vacuumed dust to go back in the room where the stove is located.

Before you begin with routine maintenance, including cleaning, you should take over the follow precautions:

- switch off the stove from the power supply before you begin any works,
- before you begin any works, make sure that the ash and the ashtray are cold,
- with a vacuum cleaner clean the ash from the combustion chamber **every day**,
- with a vacuum cleaner carefully clean the firebox **every day** (after each use and when the stove gets cold), **once in every two weeks**

from the chamber pull out the upper plate made of steel or cast iron (figure 20) by lifting, straightening, lowering in the height of the chamber opening and by turning so that one of its ends along the height comes out first and then completely take out the upper plate from the chamber and put it aside, on the floor. Then maximally lift the cast plate in the chamber (figure 20B) and by using a vacuum cleaner, clean the back part of the chamber behind plate B. You can perform this cleaning also by taking out the upper metal sheet deflector for the purpose of cleaning the glass (figure 21D). This sheet metal is attached to screws as shown in figure 21 (D). Then pull out the upper plate of steel or cast iron (figure 20A) and turn it and pull out the lower, back plate of cast iron (figure 20B). Clean the parts, shown in figure 21. We do not recommend this other manner of cleaning since damaging of the threads of the special bolts of the deflector may quickly occur.

IMPORTANT NOTICE:

-During returning of the cast protective plate B, you must strictly make sure that the bottom part of plate is placed behind two limit teeth which are located at the left and the right side of the chamber, down. The plate must never be placed in front of the limit teeth. You must also compulsorily check the inlet pipes from the snail box through which the pellets pass and fall as well as the firebox and the protective cast plate B. There must not be any cogs, but only a flat transition from the lower side of the composition on the same so that the pellets could fall easily and so that it won't be kept and accumulated in the inlet pipe, and then easily ignited in the very inlet pipe. If the protective plate is improperly placed, ignition of pellets may occur in the pellet storage which may cause negative consequences.

-For improper placement of the protective plate B and the resulting consequences, the stove manufacturer does not assume any responsibility.

- During placement of the upper plate A, the rectangular opening should be facing upwards as shown in figure 19A.

- The protective plate B and the upper plate A on the composition, are sealed by silicon from the left and the right side, so that they would not fall from their bearing during transportation. The silicon will burn during the first ignition thus enabling removal of the plate and cleaning of the space behind plate B.

Always make sure that the stove and the ash are cold.

This is a firebox (box-shaped) where the wood mass pellet combust. Look at figure 22. It is recommendable that the firebox is cleaned with a vacuum cleaner after each use (when the stove gets cold). After each third use, it is recommended to take out the firebox and to check to make sure that there is no too much ash which is accumulated on the bottom of the box-shaped firebox. Then return the box back, tightly place it to its positions to ensure safe operation of the stove.

If you have some unclear issues, do not hesitate to call an authorized service in order to get additional information and explanations, since the manufacturer does not have an insight to the stove installation and does not offer any guarantee for the installation of the stove and its maintenance.

The manufacturer does not assume any personal responsibility for the damages that happened as a result of third parties.

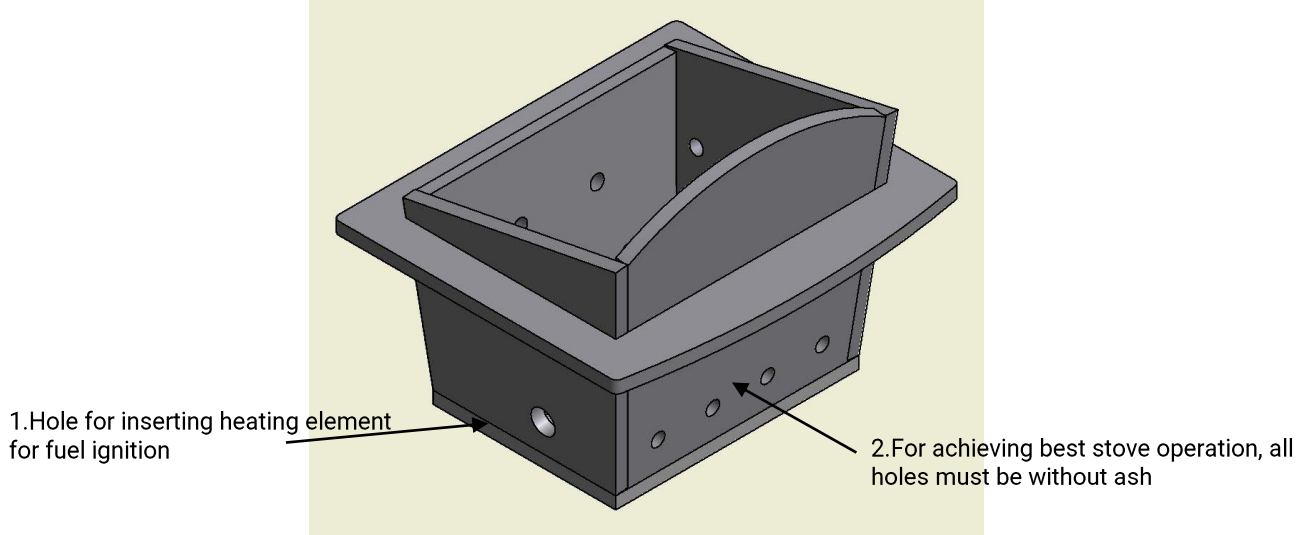

Figure 22

ASHTRAY (if it is full, you should clean it with a vacuum cleaner or empty it):

Make sure that the stove and the ash are both cold

The ashtray must be cleaned every **day or every other day**, with a vacuum cleaner or simply by disposal of the ash.

In this manner all the dirt that stays inside from the pellet combustion is removed. Then the box must be properly returned to its position. Never put pellets which have not burned in the ashtray.

- never put pellets that have not burned in the ash box or ashtray,
- clean the glass with a soft cloth.

DOOR WITH A GLASS (it should be temporarily checked and cleaned):

Make sure that the stove and the ash are both cold

The glass is made of pyro-ceramics resistant to high temperatures. In case of damage, before you start using the stove again, replace the glass as soon as possible. The glass must be replaced only by an authorized person for this.

8.2. CLEANING AND MAINTENANCE (for workers who work on maintenance)

- FLUE CHANNEL – FLUE (it should be cleaned once in every six months or after combustion of two tons of pellets)

Make sure that the stove and the ash are both cold

This smoke exhaust channel (flue), is resistant to wind and must be checked and cleaned every other year, best is at the beginning of the heating season. For professional cleaning of these elements of the system, the best is to contact authorized professional technicians. The spots to which you should pay special attention during cleaning and which should be separately cleaned, are shown in figure 23b.

- INTERNAL FIREBOX (every two weeks)

Make sure that the stove and the ash are both cold

For proper cleaning, use a vacuum cleaner to remove the ash behind the cast place every two or three weeks, by turning or removing the plate as shown in point 6.1 (figures 19,20,21).

- EXHAUST SPACE OF THE SMOKE EXTRACTOR (it is checked and cleaned once in every six months)

Make sure that the stove and the ash are both cold

The cleaning of the internal space for the smoke exhaust is performed first by removing the cover, that is, by taking out the lower ashtray and the hose of the vacuum cleaner is inserted through that opening, so the remaining ash is taken out with the vacuum cleaner, and proper operation of the stove is obtained, figure 23b.

- GENERAL CLEANING AT THE END OF THE HEATING SEASON

Make sure that the stove and the ash are both cold – switch off the stove from the power supply

At the end of the season, for safety purposes, switch of the stove from the power supply. It is very important to clean and check the stove, as explained in the points above.

Make sure that the stove and the ash are both cold

After longer period of use, it may occur that the non-asbestos tape (lane) for sealing (gasket) on the door is detached This seal is affixed to the door by using silicone resistant to high temperatures. In order to resolve this, attach the back end (the back part of the tape) of the sealing tape by using glue which is resistant to high temperatures. This is very important for good sealing of the door.

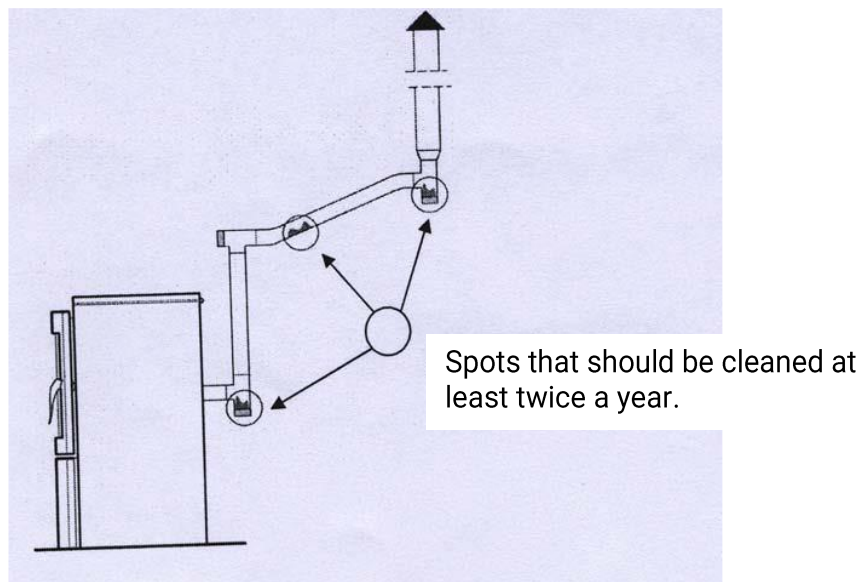

Figure 23a. Spots that should be cleaned at least twice a year

8.3. SPECIAL MAINTENANCE

Your stove is a thermal generator that uses pellets as solid biofuel. For this reason special cleaning should be performed once in a year.

The best is to perform the previously explained works at the beginning of the heating season.

The purpose of this special maintenance is to provide proper and efficient stove operation.

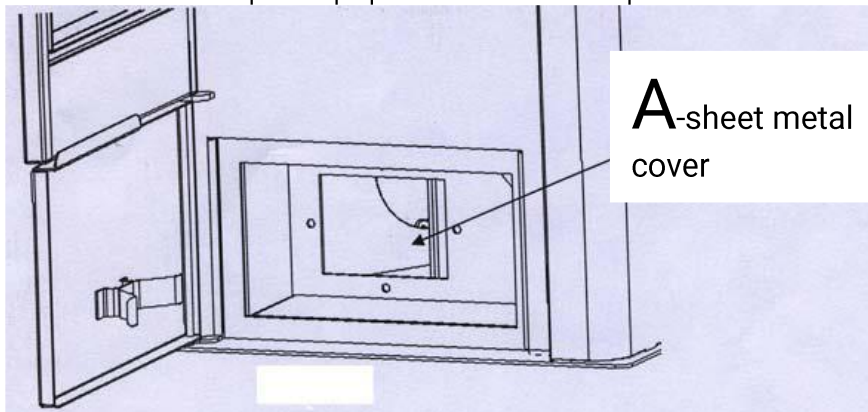

Figure 23b

A - Remove the sheet metal cover and clean the internal part with a vacuum cleaner.

9. IMPORTANT SAFETY MEASURES

You have bought a product with the highest quality.

The manufacturer is always at your disposal to provide you all the information you need in regard to the stove and the instructions for assembly and installation in your geographic conditions. Proper installation of the stove, in accordance with the instructions given in this instruction manual, is necessary for the purpose of prevention of danger, fire and any irregularities or malfunctioning.

The stove functions with negative pressure in the combustion chamber. For that purpose, make sure that the smoke exhaust is well thermally sealed.

DANGER

In the event of fire in the smoke exhaust pipe, keep all people and pets away from the room, immediately switch off the power supply by using the main switch in the house or by pulling the plug from the wall (the plug must always be easily reachable and free), and immediately call firemen.

DANGER

Typical wood for stoking cannot be used.

DANGER

Do not use the stove for burning waste.

10. THE QUALITY OF PELLETS IS VERY IMPORTANT

This stove has been designed to use pressed wood (pellets) as fuel.

Since there are many products of this type on the market, it is important that you choose pellets as fuel which is not dirty. Make sure to use quality pellets which are compatible with a little dust as well.

Ask your vendor or the stove manufacturer about the best pellets, whose diameter should be about 6 to 7mm and a length of about 30mm. **Proper operation of the stove depends on the type and quality of the pellet fuel, since the heat obtained from different types of products can have different intensity.**

The manufacturer of the stove does not assume any responsibility about the use of the pellet fuel with inappropriate quality, neither about the bad operation of the stove which is a result to that fuel.

10.1. STORAGE OF PELLET FUEL

The pellets must be stored in a dry and not too cold room. Cold and wet pellets (with a temperature of about 5°C) reduce the thermal strength and required more frequent cleaning of the stove.

THE PELLETS MUST NOT BE STORED DIRECTLY CLOSE TO THE STOVE. Store them at least 2 meters from the stove. Carefully manipulate with pellets, do not break them.

WARNING:

In case of placement of sawdust or small – crumbling pellets in the funnel part of the stove i.e. the fuel tank, this may to block the dosage system of pellets (fuel). Such pellet may lead to disturbances in the operation of the electro-motor that which drives the mechanism for inserting pellets, or may cause damaging of the redactor which operates in connection with that electro motor. If at the bottom of the pellet tank, that is, on the bottom of the snail transmission, when the tank is empty, you notice such small, crumbling pellet, clean it with a vacuum cleaner by placing the vacuum cleaner hose through the openings of the pellet grate.

11. DESCRIPTION AND FUNCTIONING OF THE ELECTRONIC CARD

11.1. DESCRIPTION OF THE ELECTRONIC CARD (KEYBOARD) (figure 24)

Button 1: it increases the room temperature, shows the temperature of the chamber

Button 2: reduces the room temperature

Both these buttons have program functions.

Button 3: modification of the temperature and program functions

Button 4: switched on/ switched of (ON / OFF) and exit from programs

Button 5: reduces the heat capacity from 5 to 1

Button 6: increases the heat capacity from 1 to 5

WARNING

Automatic programming of the ventilation with values from 1 to 5 has been factory adjusted and can be changed only by authorized professional repairmen, and factory experts. They are informed from each separate case.

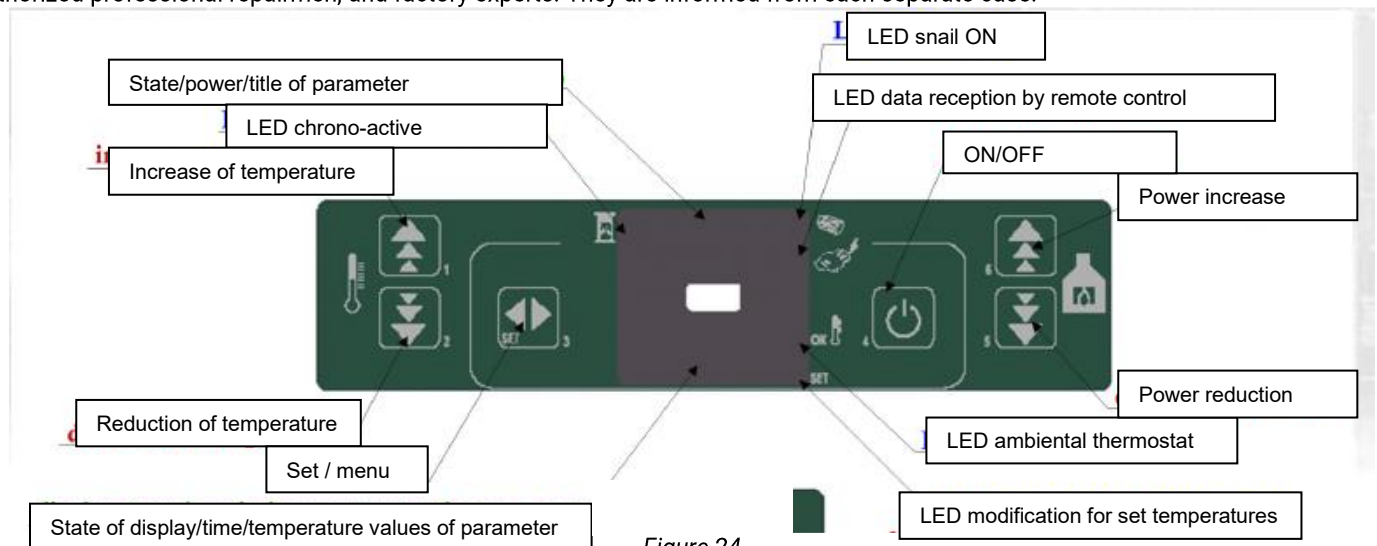

Figure 24

Electronic keyboard of controls

LED → Light Emitting Diode → Lamp

11.2. FUNCTIONING OF THE ELECTRONIC CARD

When it is already connected to the power supply, you should turn the switch which is located at the back side of the stove into position 1. Then the following indication as shown in figure 25 appears:



Figure 25

In order to start the stove, press button 4. Shortly after this, the command to the electronics will put the stove into a state of calibration, that is, preparation for work and the message shown in figure 26 appears on the display. The suction device will be switched off for about 15 seconds, that it will be switch on again for maximum 7 seconds.

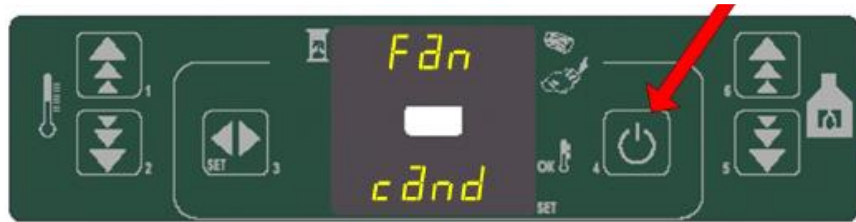

Figure 26

Upon termination of this stage, which lasts about 20 seconds, the message "LOAD WOOD" appears as shown in figure 27. The snail loader loads the pellets and the ignition heating element is on. This is shown on the display of the control keyboard through the previously described LED lamps.

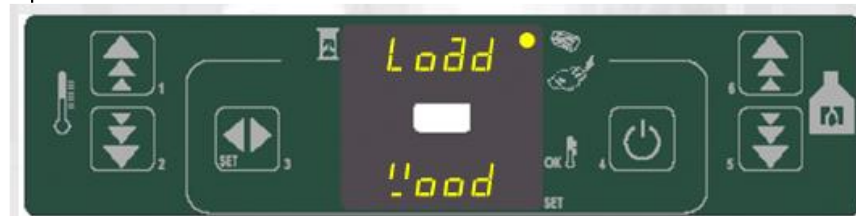

Figure 27

When the temperature is sufficiently high (after about 15 minutes), reach in accordance with a certain coefficient (about 3°C per minute), the electronic command prepares the fuel ignition and the next stage of operation follows, flame stabilization and then the display of the command board shows the message "FIRE ON" (activated flame) as in figure 28. The tangential fan (alternator) switches on at that moment as well.

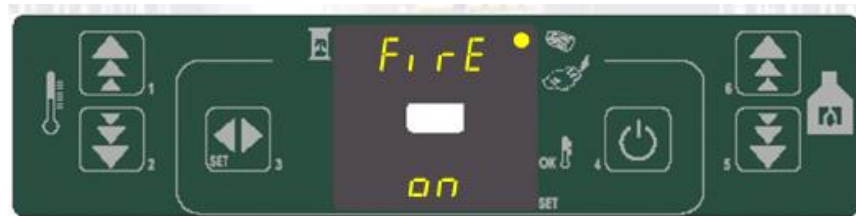

Figure 28

Upon termination of the stabilization stage (the standard duration is about 2 seconds), the control of the electronic unit goes to an operation mode, showing the selected heating power (which may be changes by means of the buttons 5 and 6) and the ambient temperature Figure 29.

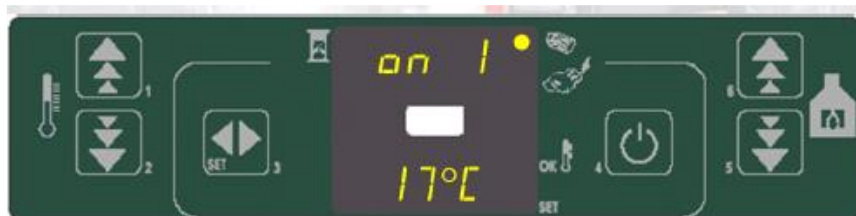

Figure 29

In this stage the buttons 5 and 6 adjust the stove energy from 1 to 5, provided that the ambient temperature is less than the determined set temperature*.

On the contrary, the heating energy is set to a minimum.

* Actually, the stove is set to an ambient temperature. After reaching the desired temperature (manually adjusted – look at the chapter with description of the modification of ambient temperature), the stove adjusts its operation to a minimum and in that case it is not possible to change the heating energy.

Of the pellet d fuel does not ignite, the stove will try once more to ignite the fuel. If the pellet ignition does not succeed once again, this will be indicated with an alarm.

The speed of the device for air suction and the fan, as well as the time required for furl ignition through the heating element, are parameters which can be adjusted only by authorized professional repairmen, factory exports.

Once connection to the power supply is established, upon stoppage of electricity for a certain period of time, the control of the electronics enables discharge of the remaining smoke with an increased speed of the air suction device and then the display shows the following message "COOL FIRE". Once the cooling is over, then the fuel ignition starts once again.

IMPORTANT NOTICE

The stove normally switches on after about 15 minutes, with a good quality of the pellet fuel and with an ambient temperature of 11 degrees. If the ambient temperature is lower and the spark plug functions normally, cancellation of the stove ignition may occur. If this happens, you should switch off the stove by pressing the button 4. Then take remove and empty the cast burner (figure 22) where the pellets fall and combust. Return the cast burner to its position in the stove and once again start (restart) the stove by pressing button 4 for few seconds.

- **In order to bypass i.e. to circumvent the stage of starting of the stove**, press button 6 with a duration of 2 seconds. This leads directly to the operational stage of the stove. Note: Use this only when the stove is switched on and with an active flame in the stove.

- **In order to change the set ambient temperature** (this is the desired temperature of the room where the stove is located), at any moment press the button 3 and use the buttons 2 and 1 to adjust the temperature indicated on the lower display. When the button 3 is pressed, the lower part of the control board indicates the set ambient temperature (the one you would like to achieve).

- **In order to manually set the room ventilation, press button 3. The indication "SET X" is shown on the display where the flickering letter X represents the speed of the exchanger ventilator, which may be changed by using the buttons 5 and 6 and which may have the following values:**

A = AUTOMTIC speed of the exchanger follows the real indicated energy

1 = SPEED 1 (speed 1)

2 = SPEED 2 (speed 2)

3 = SPEED 3 (speed 3) are all possible manual fan adjustments

4 = SPEED 4 (speed 4)

5 = SPEED 5 (speed 5)

- **In order to check the stove temperature**, press button 1. The lower display on the control board shows the temperature, while the upper display shows the number of rotations of the smoke suction motor.

- **Switching off of the stove** occurs once you press button 4. The upper display shows the message OFF (switched off) and the flow of pellet fuel into the firebox is stopped. After cooling, the tangential fan switches off (stops working) and after 10 minutes from the moment of cooling, the suction device switches off as well. The switching off speed of the smoke suction device is a parameter which may be set only by an authorized repairman.

NOTE: Even when the stove is cold, switching off of the smoke suction device occurs after about 10 to 15 minutes.

For this reason DO NOT switch off the stove from the main switch (0-1) one the stove is switched off (OFF). Wait until the switching off cycle is finished, that is, after cooling of the stove as it is previously described.

11.3. PARAMETERS USED BY THE STOVE USER

(Press button 3 to access the parameters)

Every time when you press this button you may get one of the following parameters with the corresponding functions given here:

Use buttons 1 and 2 to change the value of the parameters

UT01: day in the week. Day 1 ... Day 7 or OFF to show that the programming is switched off

UT02: change the current hours

UT03: change of minutes

UT04: button for access to technical parameters (reserved). **DO NOT TOUCH. THE PARAMETERS ARE FACTORY ADJUSTED AND RESERVED FOR EXPERTS AND TECHNICAL STAFF OF THE STOVE MANUFACTURER.**

UT05: change of the starting time (program 1) in stages of 10 minutes

UT06: change of the switching off time (program 1) in stages of 10 minutes

UT07: change of program 1, active / inactive, days in the week with the button 2 and going over through the days with button 1.

Confirm and proceed with button 3.

UT08: change of the starting time (program 2) in stages of 10 minutes

UT09: change of the switching off time (program 2) in stages of 10 minutes

UT10: change program 2, active / inactive, days in the week with button 2 and going over through the days with button 1.

Confirm and leave the parameters with button 3.

UT11: change of the starting time (program 3) in stages of 10 minutes

UT12: change of the switching off time (program 3) in stages of 10 minutes

UT13: change program 3, active / inactive, days in the week with the button 2 and going over through the days with button 1.

Confirm and proceed with button 3.

UT14: change of the starting time (program 4) in stages of 10 minutes

UT15: change of the switching off time (program 4) in stages of 10 minutes

UT16: change program 4, active / inactive, days in the week with button 2 and going over through the days with button 1.

Confirm and leave the parameters with button 3.

NOTE: In order to go to the next parameter, use the button 3 (adjustment), button 1 for increasing and button 2 for reduction.

NOTE: You can leave the program at any time by pressing button 4.

The stove programming enables that you program the starting and the switching off of the stove four time in one day, seven days in the week (with the day 1 that indicates the day when the first programming has been performed).

Setting the time

You can set the operation of the time and it can be seen on the lower red indicator of the keyboard. When you're programing the operation of the time, it functions also when the stove is not switched on since it is charged by a battery.

You must adjust the time if you want to program the stove operation, that is, if you want to program automatic switching on and switching off of the stove.

The procedure for adjustment of the time is the following:

Press the button 3 twice until the flickering message **UT01** appears.

At that moment, press the buttons 1 and 2 to adjust the day in the week (day 1 corresponds to Monday, continuing further to day 7 which corresponds to Sunday). Adjust the day when you make the adjustment of the time (for example, if it is Monday, set DAY1).

Then press the button SET once you set the day. The display shows a flickering message **UT02**. Now here you can set the time by using the buttons 1 and 2. After you press the button SET one more time (to confirm the inserted time), the flickering message **UT03** appears and now you can change the minutes of the time again by using the buttons 1 and 2.

After setting the minutes, press the button SET once again to get the message **UT04** which corresponds to the programming of the technical parameters (use only authorized repairmen).

Once you have adjusted and confirmed the operation of the clock, the LED lamp 1 (left, up) on the keyboard will switch on and will stay on. Temporarily recontrol the accuracy of the clock and if it is disrupted you can adjust it once again according to the manner described above.

In order to come out of the program at any time, press once the button for switching off the stove (button 4) in duration of not less than 2 seconds.

Automatic starting and switching off of the stove

If you want automatic starting and switching off of the stove, the clock must be adjusted as described.

Once you've adjusted the clock and reached the parameter **UT04**, press SET once again to go to **UT05**. Now here you can select the time of starting for the program of the first automatic starting of the stove, again by using the buttons 1 and 2.

We would like to remind you that the stove starting and switching off can be programmed four times in one day, seven days in the week. The first cycle of starting/switching off takes place through the program 1, with presented parameters **UT05, UT06** and **UT07**. Another cycle of starting/switching off takes place through the program 2 and it can be modified through the parameters **UT08, UT09** and **UT10**. The third program is performed with the parameters **UT11, UT12, UT13** and the fourth program is performed through the parameters **UT14, UT15** and **UT16**.)

Once you adjust the starting time for the first program, use the button SET to move to parameter **UT06**, where you can adjust the switching off time of the stove, again by using the buttons 1 and 2.

Once you confirm the selected switching off time by using the button SET, then you go to parameter **UT07**, where you determine, that is, you set the days in the week when the previously defined program of starting / switching off will be active, that is, when it will act.

Then the message "ON1" appears. This means that on day 1 (previously defined with the parameter **UT01**) the first program of starting/switching off will be active i.e. it will act at that moment. In order to switch off the automatic starting, switching off of the stove on that day, now press the button 2 and the display will show the message OFF1 (switched off programming for that day).

If instead of that you press the button 1, go to day 2 ("ON2") where in the same manner you can activate or switch off the first starting program with button 2.

Continue in the same manner to activate/deactivate the programs for the remaining days in the week.

After programming the starting/switching off of the stove operation for different days in the week, once again press the button SET in order to get access according to the sequence of parameters **UT08, UT09** and **UT10**, which represent the parameters for adjusting another program for starting/switching off the stove, which can be memorized.

In order to turn off, that is, to delete all weekly and daily programs for starting and switching off of the stove for program 2 (when there is no more flickering of the UT parameter), press the button SET until UT10 appears on the display, then select OFF from the given selection by pressing the buttons 1 or 2 for all 7 days, separately for each day.

If you want to turn off, that is, to delete the programmed starting and switching off of the stove of the program 1, you should press SET to get to UT07, for program 2 to get to UT12, for program 4 to get to UT16 and in the described manner as for program 2 (UT10) cancel all programs for starting and switching off of the stove for all days (everywhere it should be OFF-switched off).

11.4. ALARM MANAGEMENT

An alarm signal (meaning that the stove informs about the occurrence of a certain problem with a sound signal) appears in the following cases:

ORIGIN OF THE ALARM	INDICATION ON THE DISPLAY
Probe for smoke temperature	ALARM SOND FUMI
Probe for smoke temperature	ALARM HOT TEMP
Failed ignition	ALARM ACC NO
Stoppage of stove operation	ALARM NO FIRE
Lack of power supply	ALARM NO RETE
Safety pressure switch of the snail (spiral)	ALARM DEP NO
Thermostat for general safety	ALARM DEP NO
Pressure switch	ALARM DEP NO

Table 8

In case of irregularities of the operation, the following procedure is activated:

- 1) The system for automatic pellet filling switches off
 - 2) The smoke discharge fan operates with a full maximal capacity for maximum twenty minutes.
- Before switching the stove once again, wait that it gets completely cold and then press the button „4“ (on/off). If the stove is not cold, the message „AttE“ is shown as in figure 30.



Figure 30

11.4.1. Alarm dEP no (pressure alarm – alarm of the pressure switch)

It occurs when irregularities occur related to:

The flue pipe hardly pulls which causes poor, insufficient pressure.

If the alarm continues occurring, check whether the stove of the flue should be serviced.

The smoke pressure switch controls the negative pressure in the stove chamber due to improperly closed door or ash box, or due to some obstacles in the smoke outlet. In this case, the display shows the message **ALAr dEP no** (Figure 31), the smoke motor functions maximally and then it switches off after 10 minutes.



Figure 31

11.4.2. Alarm ALAr Sond (alarm of the probe for flue gases)

It appears when an error occurs in the smoke detection probe, when the probe is broken or it is not connected.

The stove begins the switching off procedure while the alarm is switched on.

Alarm of the smoke probe: if some malfunction occurs at the smoke probe, the display shows the message "SOND FUMI ALAR", and in this case the fan and the smoke suction device function with full power.



Figure 32

11.4.3. Alarm ALAr hot (alarm for excessive smoke temperature)

It occurs when the probe for flue gases indicates too high temperature (more than 280°C)

The stove begins the switching off procedure while the alarm is on.



Figure 33

11.4.4. Alarm of the chamber:

This alarm appears when the temperature of the stove chamber is too high and then the message "HOT TEMP ALAR" appears. In order to prevent the occurrence of this alarm to certain temperature limits, the smoke suction device and the exchanger must function at their maximum, and the fuel pellets are minimally inserted. In order to return to normal operation, press the button 4, for 3 seconds until the boiler returns back to ON (switched on) state.

11.4.5. Alarm for overheating of the chamber or temperature of the snail distributor for pellet supply:

It occurs if the main safety thermostat from 80°C or 180°C reads a temperature higher than the allowed. The message „ALAr dEP no“ appears (Figure 34) and the system stops. This alarm appears when the temperature of the chamber or the temperature of the funnel for pellet inlet is too high, and in this case the following message appears "ALAr dEP no". This is one additional safety mechanical device. In order to return to normal operation, you need to wait for the stove to get' cold (the fans for smoke and for cooling are in function). This cooling lasts about twenty minutes. Then restore the function of the safety thermostat that has blocked the stove operation (by unscrewing the plastic cover and manually press the thermostat button until a silent metal sound is heard) which is located in the lower back part, above the main switch (0-1) Figure 17 and then press the button 4 in a duration of 3

seconds until the stove returns back to it ON (switched on) position. The upper thermostat blocks the stove operation when the stove chamber heats at 180°C and the lower one when the case of snail transmission heats at 80°C.

NOTE: If one of these two last alarms is active, make sure that the chamber is not clogged with ash and that the flue is not partially clogged.



Figure 34

11.4.6. Alarm for failed ignition

It triggers when the ignition stage failed and the following message appears „ALAr Acc no“ (Figure 35). The switching off procedure immediately activates.

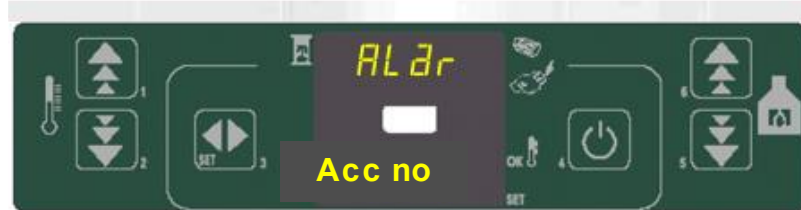

Figure 35

11.4.7. Alarm for power outage

When the stove is switched on, a power outage stops the operation of the electrical devices on the stove. When the power supply returns, an alarm signalization occurs as shown in figure 36:



Figure 36

11.4.8. Alarm ALAr Fan (alarm for discharge fan)

If the smoke discharge fan does not function well, an alarm occurs – ALAr FAn FaiL (Figure 37). The stove begins the procedure of switching off while the alarm is on.



Figure 37

11.4.9. „StoP FirE“ (it is not an alarm)

StoP FirE“ mode can be activated in adjusted intervals, during normal operation. Cleaning of the stove is performed. A message „StoP FirE“ is shown (Figure 38).

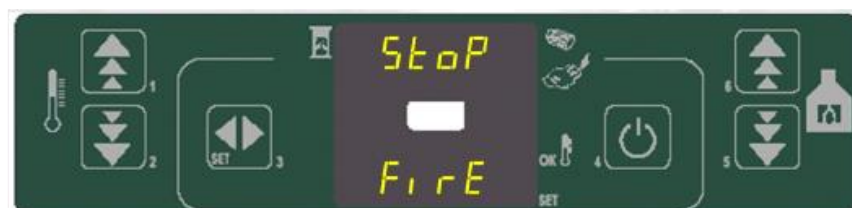

Figure 38

By pressing the button 4 you can delete, that is, remove a message from the display. The alarm signals are followed by a sound signal.

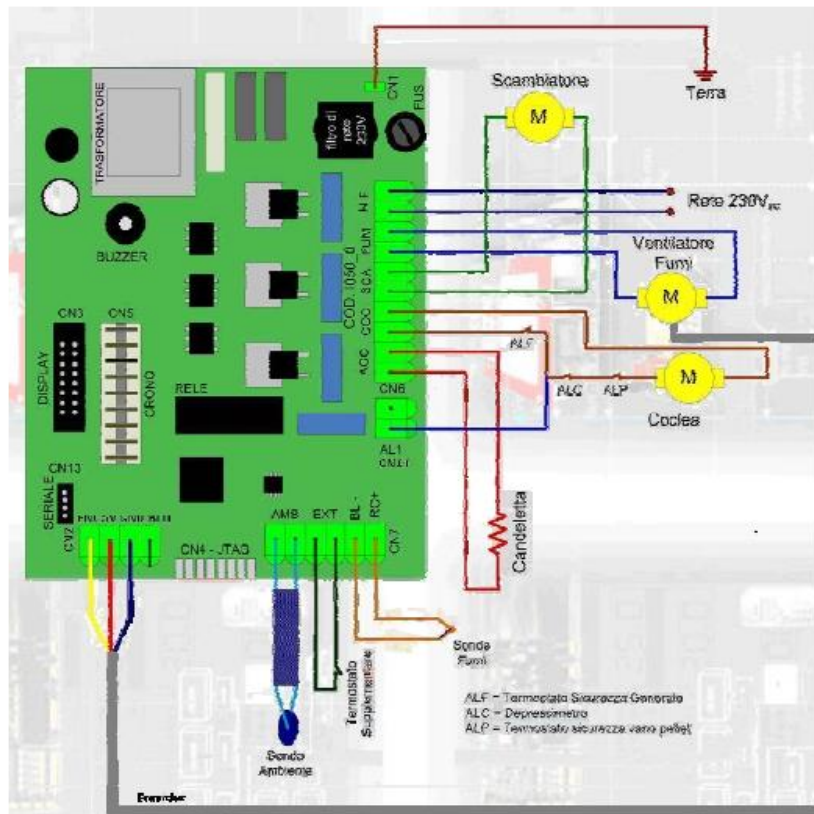

Figure 39 - Electronic card

11.5. OPERATION WITH AMBIENT PROBE ON STOVE

The stove can be switched on/off manually or in a programmed way.

The stove modulates the power depending on the ambient temperature measured by the on-board probe (that is, the stove tries to maintain the desired temperature, consuming as little as possible).

If the user has enabled the "Standby" function, rather than modulate, the stove will turn off when the set temperature is reached, then re-ignite when the ambient temperature falls below the set delta.

The desired ambient temperature can be set using the keys \uparrow \ominus \downarrow .

PROBLEM	CAUSE	SOLUTION	
The control display won't turn on	The stove is without power	Check that the plug is connected to the mains.	USER
	The safety fuses in the electrical socket are blown	Replace the safety fuses in the electrical socket (3.15A-250V).	TECHNICIAN
	Faulty control display	Replace the control display.	TECHNICIAN
	Faulty flat cable	Replace the flat cable.	TECHNICIAN
	Faulty circuit board	Replace the circuit board	TECHNICIAN
Pellets are not reaching the combustion chamber	Tank empty	Fill the tank.	USER
	Fire door open or pellet door open	Close the fire door and pellet door and check that there are no pellet granules along the gasket.	USER
	Clogged stove	Clean the flue gas chamber.	USER
	Auger blocked by a foreign object (such as nails)	Clean auger.	TECHNICIAN
	Broken auger gearmotor	Replace the gearmotor.	TECHNICIAN
The flame turns off and the stove stops	Check that there are no "ACTIVE ALARMS" on the display	Service the stove.	TECHNICIAN
	Tank empty	Fill the tank.	USER
	Auger blocked by a foreign object (such as nails)	Clean auger.	TECHNICIAN
	Expired pellets	Try other types of pellets.	USER
	Pellet load value too low "PHASE 1"	Adjust the pellet load.	USER TECHNICIAN

The flames are weak and orange, the pellets don't burn properly and the glass turns black	Insufficient combustion air	Check the following items: any obstructions to the combustion air inlet from the back or under the stove; blocked holes in the burn pot grille and/or too much ash in the burn pot housing, Have the extractor blades and impeller cleaned.	TECHNICIAN
	Blocked exhaust	The flue is partially or totally blocked. Call a flue expert, who will examine the stove exhaust all the way up to the chimney stack. Have it immediately cleaned.	TECHNICIAN
	Clogged stove	Clean the inside of the stove.	USER
	Broken flue gas extractor	The pellets can also burn thanks to the vacuum in the flue, without the aid of the extractor. Have the flue gas extractor immediately replaced. It may be harmful to human health to operate the stove without the flue gas extractor.	TECHNICIAN
The exchanger fan continues to turn even if the stove has cooled	Defective flue gas temperature probe	Replace the flue gas probe.	TECHNICIAN
	Faulty electronic circuit board	Replace the circuit board.	TECHNICIAN
Ash around the stove	Faulty or broken door gaskets	Replace the gaskets.	TECHNICIAN
	Flue gas ducts not sealed	Consult a flue specialist, who will immediately seal the connectors with silicone for high temperatures and/or replace the pipes themselves with new ones that satisfy current regulations. Non-hermetic flue gas ducting may be harmful to human health.	TECHNICIAN
The stove is at maximum power but doesn't heat	Ambient temperature reached	The stove runs at minimum. Raise the desired ambient temperature.	USER
Stove at full power and the display shows "Over temperature flue gases"	Flue gas outlet limit temperature reached	The stove runs at minimum. The problem must be checked by a technician.	TECHNICIAN
The stove's flue gas ducting creates condensate	Low flue gas temperature	Check that the flue is not clogged.	USER
		Increase the reduced stove power (pellet feeding and fan rotation).	USER
		Install condensate collection trays.	TECHNICIAN

Table 9

12. INFORMATION REGARDING DISPOSAL (THROWING OUT) AND DISASSEMBLY (SEPARATION) OF THE STOVE

The disassembly and throwing out i.e. disposal of (an old, used) stove is only a responsibility of the stove owner. The owner must act in accordance with the valid regulations of his country regarding the safety and protection of the natural environment. The disassembly and disposal of the stove may be assigned to a third entity provided that it is a company that is authorized for collection and disposal of such materials.

NOTE: *In all cases you must adhere to the valid legal regulations of the countries in which the stove is installed, in regard to disposal of such materials (objects) and, if necessary, to report the disposal of such objects.*

ATTENTION

Dissassembly of the stove must be performed only when the stove chamber does not operate and when the stove is switched off from the mains (it does not receive power supply).

- *remove all electrical parts,*
- *throw away the battery, the electronic card in the appropriate containers in accordance with the standards,*
- *separate the batteries which are stored from the electronic card,*
- *disassemble the structure of the stove with the assistance of a company that is authorized for this*

ATTENTION

Disposal of the stove in public locations represents serious danger for people and animals. In such cases, the owner is always responsible for injuries of people and animals.

When the stove is disassembled, the EC designation, this instruction and all remaining documentation that refers to the stove, must be destroyed.