



METAL INDUSTRY D.O.O
17500 VRANJE, SERBIA
Radnička 1, Tel.: 017/421-121

SOLID FUEL STOVE

Amelia



INSTALLATION AND OPERATION MANUAL

ENG_v.1.0

1080067

DEAR CUSTOMERS!

Thank you for the purchase of our product.

You have chosen a good quality and economical product, the result of our long-term experience in the production of solid fuel stoves.

Hopefully we have managed to meet your requests completely, both regarding design and the size of residential area to be heated.

Prior to the stove installation please read this manual and respect all instructions.

It is necessary to comply with the effective construction rules and regulations on firebox, as well as all required local, national and European standards.

Important notes:

Never manipulate fireplace by holding cast top plate!

The fireplace should be manipulated only while it is packed. The packed stove should be brought to the location where it would be installed and only then it should be unpacked (figure 1). It should be moved by holding its lateral sides or by using ropes below the fireplace. Fireplace lifting should never be performed by holding its top cast iron plate because the sealing of top plate could be damaged which could compromise the performances of fireplace.

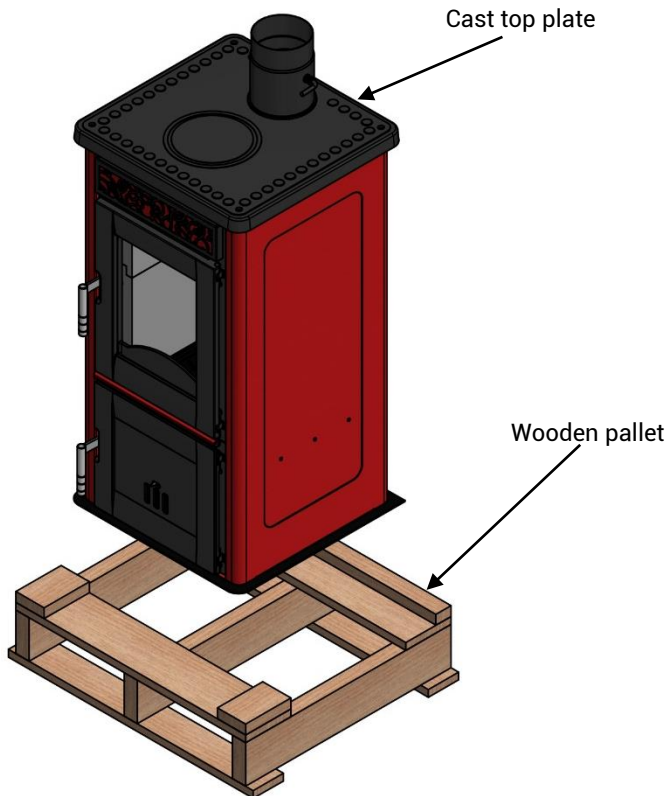

Figure 1. Unpacking stove at location where it will be installed

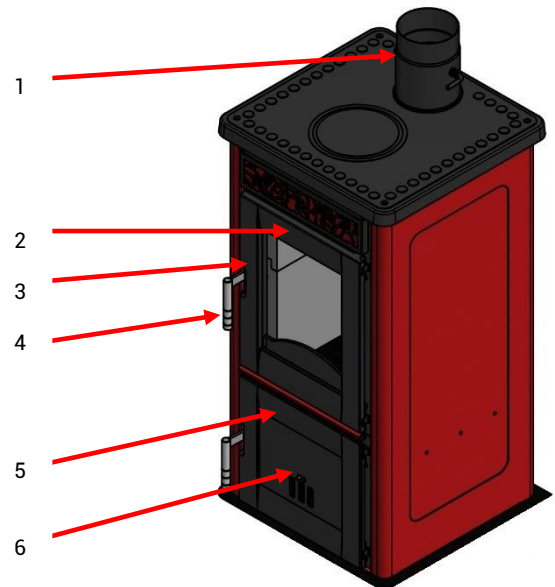

Figure 2. Solid Fuel Stove

1. Control of flue gas
2. Secondary air inlet
3. Combustion chamber door
4. Handle
5. Ashtray door
6. Primary air regulator

CAUTION!

SURFACES CAN BE VERY HOT!
BE VERY CAREFUL



For the proper stove operation you should read carefully this manual and follow the stated instructions.

During combustion, thermal energy is released, which significantly influences increasing temperatures of surfaces, doors, handles, glass and exhaust gases. Avoid contact with those elements if you are not wearing protective equipment (including a protective glove).

Ensure that children are aware of the risks and keep them away from the stove during operation.

Packaging components can be dangerous for children and adults with disabilities. There is a risk of injury. It is necessary to remove all components in a safe place.

Replacement parts, other than our tested original parts, must not be used on the stove. **Alfa Plam is not responsible for the consequences of upgrading the stove.**

The air inlet or flue gas outlets must not be reduced.

The area where the appliance is installed should have satisfactory fresh air supply. If the windows and doors are well sealed, or if other air-consuming appliances such as a steam cleaner, a tumble dryer, a fan, etc., are installed in the area where the stove is placed, and take air, in such circumstances, air for combustion (fresh air) should be led from outside.

Use only recommended types of fuel – namely wood logs.

The necessary discharge pressure (chimney draught) should be 12 Pa during normal workload. If the pressure exceeds 15 Pa, throttle valve spacer should be used for the discharge pipe.

The ashpan must not contain any flammable materials. The filling level should not exceed the height of lateral sides to the ashpan.

⚠ Caution!

The door and the section containing ash should always be closed (except in lighting fire, fuel supply and cleaning up ash) to prevent the escape of hot air.

It is not allowed to do modifications on the stove, except with the use of recommended and inspected original parts and provided that the works are performed only by our service company.

In case fire breaks out in the chimney, the stove door should remain closed with the air control damper also being closed! **Never attempt to put out fire by pouring water down the chimney.** Due to water vapor created in the chimney there is a risk of explosion. In case of emergency call the fire department on their emergency helpline number!

In case of interference close all air control dampers and until the cause is eliminated do not inject new fuel into the stove!

If you follow the installation and operation instructions, the stove shall be a reliable heat source. All possible problems could be solved through our service company. In case of complaints including problems or functional errors, please contact our service company. They shall assist you in placing orders on spare parts.

Do not store flammable substances or wood under the ash box, do not store firewood in it.

⚠ ATTENTION

Important Notes

- For the proper operation of the stove, it is important to read the manual carefully and adhere strictly to the instructions contained there.

- Use only recommended types of fuel as specified by the user manual.

- Use of firewood with less than 20% moisture content is mandatory, or namely firewood stored in dry and open area for two years.

- Required discharge pressure (chimney draught) should be 12 Pa under normal workload.

Should the pressure exceed 15 Pa it is necessary to install a damper in the flue pipe.

- Chimney connected with the stove must meet the requirements provided by the user manual.

- In order to connect the appliance with the chimney, you must never use flexible hoses, instead use only steel flue pipes.

- Regular maintenance and care, such as cleaning the stove and flue pipes, is important for safe operation, especially in terms of appliance cost-efficiency and preservation of value.

- Unauthorized modifications are strictly prohibited and any unauthorized modification shall void the warranty.

- Only original spare parts made by the manufacturer may be installed.

- The installation area should be equipped with sufficient fresh air supply.

If windows and doors are sealed hermetically or other appliances, such as stove hood, dryer, fan etc. are located in the installation area, in such cases, combustion air (fresh air) must be supplied externally. In this respect you should contact an expert or competent chimney sweeper before the stove installation.

- The ash dump must not contain any flammable materials. The filling level may not exceed the height of lateral sides of the ash dump.

- Firebox door should always be closed during operation (except for stoking, additional fuel supply and ash clean-up) to prevent the discharge of products of combustion (smoke).

- In case of fire breaking out inside the chimney, the stove door should remain closed and the primary air control should also be closed. Never attempt to put out fire by pouring water down the chimney. Due to sudden formation of water vapor there is a risk of damages to the chimney. If necessary, contact fire department.

- Highly flammable materials like paper should not be kept in the fuel box. Pay attention to the level while filling up the box.

List of contents:

1.	INTRODUCTION	1
1.1	GENERAL INFORMATION.....	1
1.2	Manufacturer's Liability	1
1.3	User Profile	1
1.4	Technical Aid.....	1
1.5	Spare Parts	1
2.	Technical Data and Product Features.....	2
2.1	Recommendation in terms of Firewood	3
3.	Connection with the Chimney.....	3
4.	Installation of the Stove in the Area, Combustion Air Supply and Ventilation	6
4.1	Air Combustion Supply and Ventilation	6
4.2	Installation of the Stove	6
5.	Stove Description.....	8
6.	Air Control.....	8
6.1	Primary Air	8
7.	Stove Commissioning	9
7.1	Stove Commissioning and Operation.....	10
7.2	Maintenance and Cleaning	10
8.	Safe Operation of the Appliance	11
9.	Potential Malfunctions and Problems during Operation	12
10.	Disassembly, Recycling and Safe Disposal at the End of Service Life	12
11.	General data.....	13
12.	Information on Use and Transport.....	13
13.	Frequently Asked Questions.....	13
14.	The Nameplate.....	13

1. INTRODUCTION

The manual is intended to provide the user with all necessary actions to secure safe and proper use of the stove.

ALFA PLAM shall reserve the right to amend specification and technical and/or operating characteristics of the stove at any time, without notification.

Stove is intended for heating of residential areas. The stove is operational only with closed firebox door. During operation you should never open the door.

Intended purpose and provided configuration of the stove are the only ones approved by the manufacturer: **the stove should be used only in compliance with the manual.**

ALFA PLAM stove is the appliance to be used only indoors.

The intended purpose of the manual is to provide the user with all necessary actions to secure safe and proper use of the stove. The manual has all necessary information with regard to installation, use and maintenance of the stove. Careful adherence to the instructions in the manual shall guarantee high level of safety and performance of the stove. The manual should be saved and kept always available for consultation by both the user and service staff in charge of installation and maintenance. **The Installation, Operation and Maintenance Manual is an integral part of the stove.** If you lose the manual, you should ask ALFA PLAM for another copy. In case of resale, the user is obliged to provide new customer with the manual.

1.1 GENERAL INFORMATION

INFORMATION

When you contact the stove manufacturer, specify the serial number and identification data available in the section 'GENERAL DATA' at the end of the manual.

LIABILITY

ALFA PLAM shall assume no liability for any material damage or injury due to:

- failure to obey the recommendations and warnings contained in the manual,
- improper operation of the stove by the user,
- modifications and repairs not authorized by ALFA PLAM,
- poor maintenance,
- unforeseen events,
- use of spare parts that are not original or not intended for specified models of the stove.

Liability in terms of connection shall be assumed by the installer in entirety.

OPERATION

During the operation of the stove, you must comply with all instructions in the manual, as well as all national regulations of the country where the installation took place.

1.2 Manufacturer's Liability

The manufacturer shall deny any civil and criminal liability, direct or indirect, in the following cases:

- installation is not in compliance with applicable national regulations of the country where the installation should take place, as well as safety recommendations,
- failure to obey recommendations and warnings contained in the manual,
- installation is performed by unqualified staff without proper training,
- use is not in compliance with the safety recommendations contained in the manual,
- modifications and repairs are performed without the manufacturer's consent,
- use of spare parts that are not original or not intended for the specified model of the stove,
- poor maintenance of the stove,
- unforeseen events.

All local regulations, including regulations related to the national and European standards, must be adhered to during the use of the appliance.

1.3 User Profile

The user must be an adult and a responsible person with technical knowledge necessary for regular maintenance of mechanical parts of the stove.

Children may not come close to the stove when in operation, with the intent to play. The appliance may be used by children age 14 and older, as well as persons with diminished physical, sensory or mental capacity, provided that they are familiar with the user manual and supervised by seniors. Stove cleaning and maintenance may not be performed by children without the supervision of senior.

1.4 Technical Aid

ALFA PLAM can solve any technical problem with regard to the use and maintenance of stove for entire duration of service life.

Technical support shall be at your disposal to give answers to your questions and, if necessary, to refer you to the nearest authorized service center.

1.5 Spare Parts

You should use only original spare parts. Do not wait for the parts to wear out from use before you replace them. Replacement of a worn part before the breakage shall prevent potential accidents due to sudden breakage of parts, which may result in injury to people and damage to property.

2. Technical Data and Product Features

No.	Parameter	Unit	Comment	Amelia
1.	Pnom	kW	Rated Power	7,8
2.	Pshnom	kW	Rated Heat Output	7,8
3.	Pwnom	kW	Hot-Water Exchanger Output	/
4.	η_{nom}	%	Efficiency at Rated Heating Capacity	81,3
5.	η_s	%	Seasonal Space Energy Efficiency	71,3
6.	EEl	-	Energy Efficiency Index	108
7.	CO _{nom}	mg/Nm ³	CO Emission with 13% Oxygen at Rated Power	1209
8.	NO _{xnom}	mg/Nm ³	NO _x Emission with 13% Oxygen at Rated Power	92
9.	OGC _{nom}	mg/Nm ³	OGC Emission with 13% Oxygen at Rated Power	60
10.	PM _{nom}	mg/Nm ³	Dust Emission with 13% Oxygen at Rated Power	29
11.	p _{nom}	Pa	Minimum Flue Draught at Rated Power	/
12.	d _R	mm	Minimum Clearance between the Back and Flammable Materials	500
13.	d _s	mm	Minimum Clearance between the Lateral Sides and Flammable Materials	500
14.	d _c	mm	Minimum Clearance between the Top and Flammable Materials	>750
15.	d _p	mm	Minimum Clearance between the Front and Flammable Materials	800
16.	d _F	mm	Minimum Clearance between the Bottom of Product and Flammable Materials	1500
17.	d _L	mm	Minimum Clearance between the Front and Flammable Materials for the Front Side Radiation Zones	1500
18.	d _B	mm	Minimum Clearance between the Bottom of Product (excluding the footing) and Flammable Materials	0
19.	d _{non}	mm	Minimum Clearance between the Non-Combustible Walls	/
20.	s	mm	Protective Insulation in compliance with Manufacturer's Recommendations	/
21.	T _{snom}	°C	Flue Gas Temperature at Rated Power	288
22.	T _{class}	-	Chimney Designation in compliance with the Relevant Chimney Standard	T400 G
23.	$\Phi_{f,g nom}$	g/s	Flue Gas Mass Flow at Rated Power	7
24.	CON or INT	-	CON - whether the appliance is capable of continuous operation INT - whether the appliance is capable of intermittent operation	INT
25.	d _{out}	mm	Diameter of Flue Outlet	120
26.	W,D,H	mm	Overall Product Dimensions (width, depth, height)	455x445x875
27.	m	kg	Product Weight	105
28.	m _{chim}	kg	Maximum Chimney Load Capacity	0
29.		-	Read and Follow the Instructions in the User Manual	

Table. 1

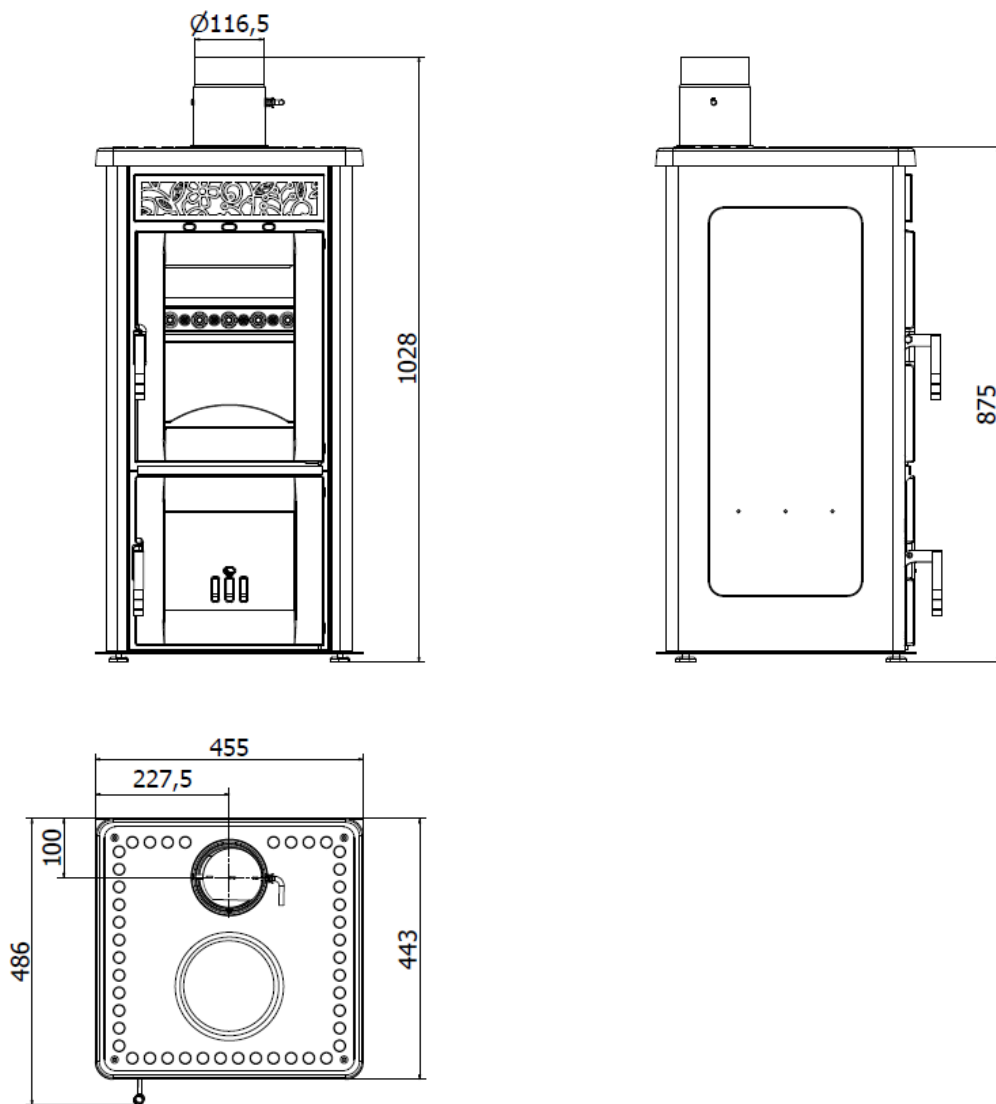

Figure 3 – Amelia - Dimensions

2.1 Recommendation in terms of Firewood

Type of Wood	kg/m ³	kWh/kg moisture 20%
Beech	750	4.0
Oak	900	4.2
Elm	640	4.1
Cottonwood	470	4.1
Larch	660	4.4
Spruce	450	4.5
White Pine	550	4.4

Table. 2

Rated Heating Capacity of Amelia is achieved during the use of the following fuel quantity:

Type of Wood	Fuel Quantity	Combustion Period	Primary Air Regulation
Beech	2,25 kg	60 min	3 mm

Table. 3

- Pay attention not to place more wood than necessary to achieve rated heating capacity. Above mentioned quantity must not be exceeded, otherwise it may lead to stove overheating.
- Wood to be used must be dry (moisture content < 20 %). That is usually the case if the wood is stored for two years in dry area with good ventilation. Wet wood has low calorific value, leading to the formation of soot deposits in flue ducts and chimney. Wood with treated outer surface (varnished, painted, veneered and impregnated), plywood, all kind of waste (packaging waste), plastics, newspaper, rubber, leather, textile etc. must not be used for heating purpose.
- Combustion of these materials would pollute the environment and is prohibited by lawmaker. In addition, damage to the chimney may occur. In that case, any manufacturer's warranty shall cease to be valid.

3. Connection with the Chimney

After the unpacking of the stove, it is necessary to read the instructions, inspect the stove and get familiar with the parts and the accessories. Pay special attention to the following:

- The door should be sealed tightly, as well as the lid on the hot plate, so the air is not introduced to the stove uncontrollably.
- Chimney connector should be sealed tightly with asbestos-free tape for the installation on side or back flue outlet, depending on the position against the chimney.

SPECIAL NOTES

- During the installation of horizontal flue pipe (in cases where necessary), flue pipe should be installed under +5° angle.
- Flue connector, flue pipes and chimney must not be narrowed;
- Connection of stove with the common flue system is not recommended.
- All connections, as well as the chimney, must be sealed tightly, without dirt and grime inside the flue pipes.

Adequate chimney and meeting of other requirements are prerequisite for perfect performance of the stove.

The stove may be installed within the kitchen area or in other adequate area, paying attention to place non-flammable base under the stove, and in case of parquetry it is necessary to place special tinplate to prevent damage to the base or fire due to negligent use.

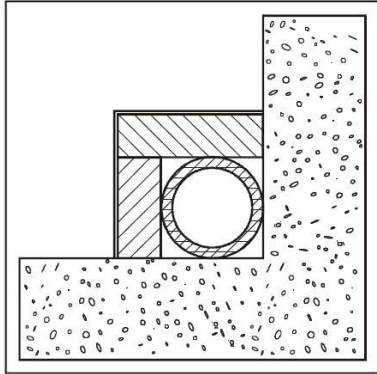

Steel chimney AISI 316 with double insulated chamber, heat resistant material up to 400 ° C. 100% optimal efficiency

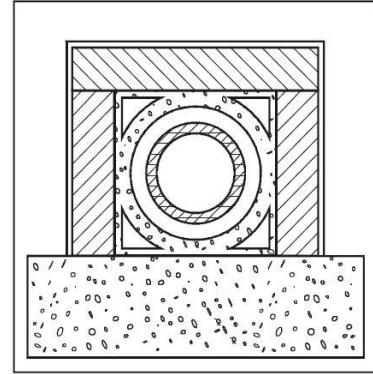

Fireproof chimney with double insulated chamber and lightweight concrete external cladding. 100% optimal efficiency

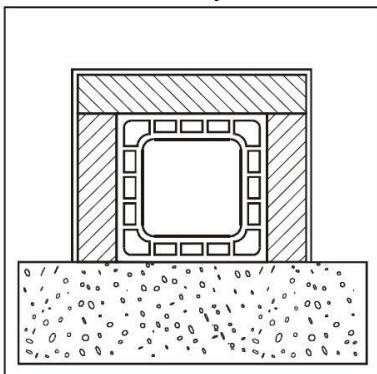

Traditional-looking chimney made of clay with depressions. 80% optimal efficiency

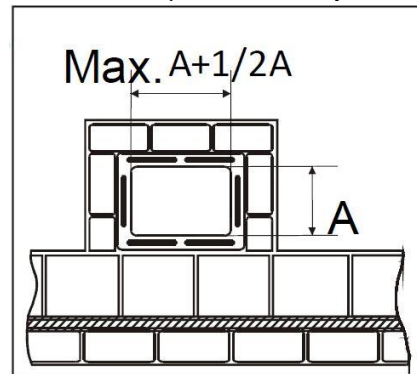

The use of chimney pipes with rectangular internal section of different ratio than planned is prohibited. 40% moderate efficiency

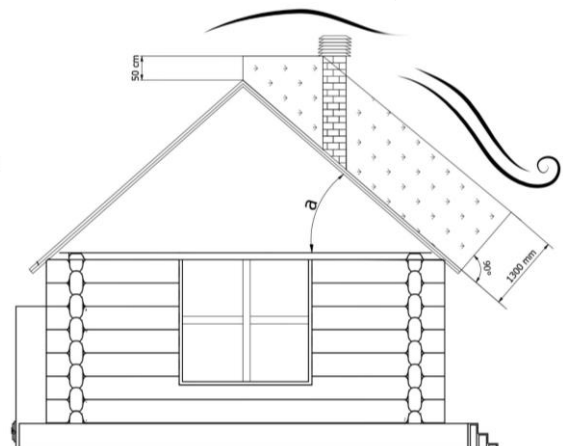
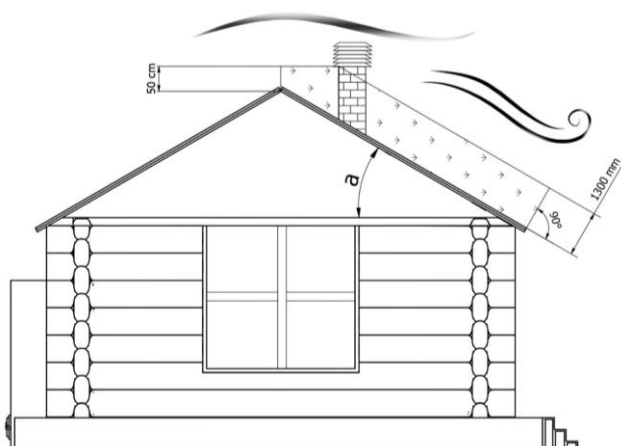

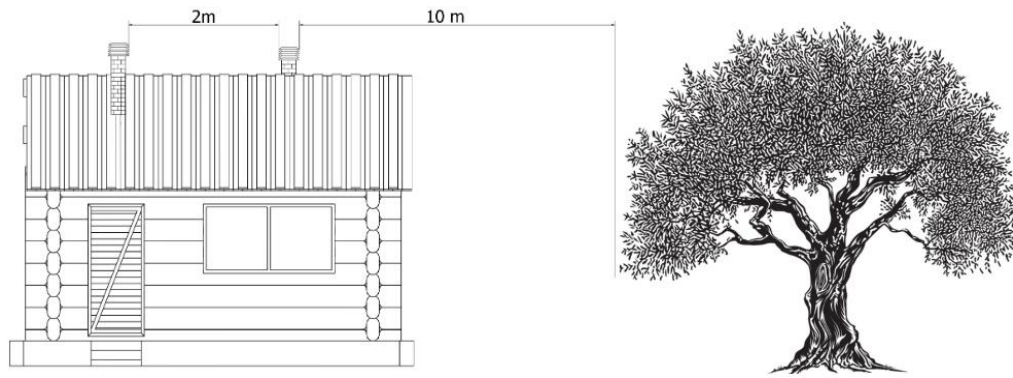



Figure 4 - Chimney – Positioning and distance

⚠ATTENTION

 Fumes created from blocked chimney are dangerous. Keep the chimney and flue pipe clean; clean according to the instructions in the manual.

Flue ducts of combustion chamber should be kept clean; clean according to the instructions in the manual. Use only recommended fuel. Read user manual.

Continuous use of the stove is not recommended. Weather conditions are in fact an important factor in the dispersion of smoke into the surrounding environment. Do not light fire when there is no wind or on a foggy day. Flue gases may be trapped inside the house and it is harmful for you and your neighbors. Wind force of 2 or less by Beaufort scale is considered to be wind free weather.

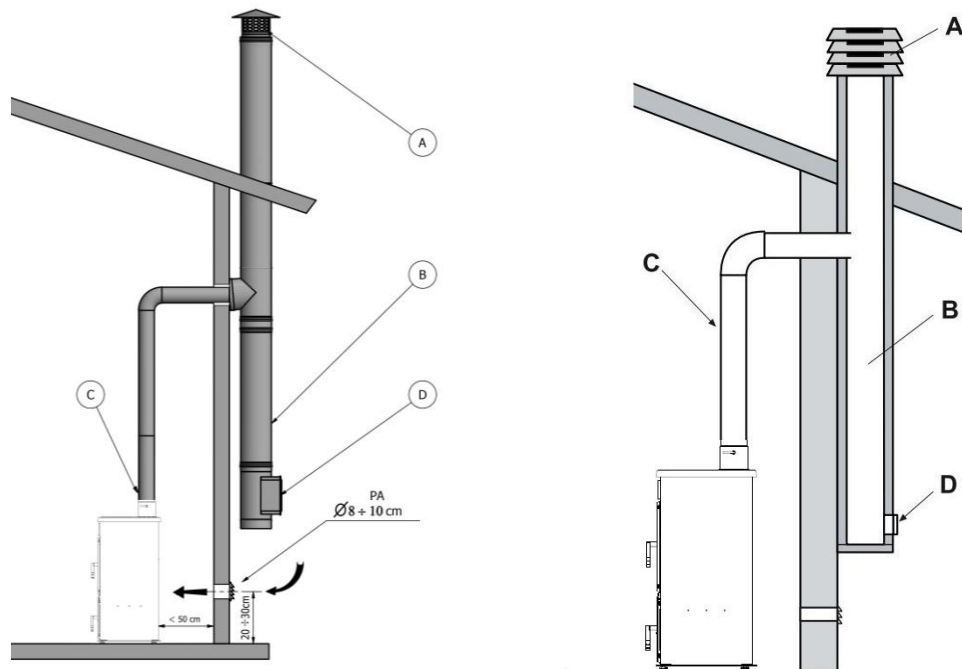

Figure 5

A - Chimney Cap

B - Chimney with minimum diameter $\varnothing 120$ mm or minimum cross-section 12x12 cm, chimney height 4-5 m as a minimum.

C – Flue Pipe $\varnothing 120$ mm

D– Chimney Cleanout Access Point

During the operation the stove shall use the air from the surrounding area. The outside air may be supplied directly by means of pipe with diameter 80 mm with a gasket as shown in *Image 2*. The air inlet must be placed at height of approximately 20-30 cm from the floor. On the outside it is necessary to place a grate for continuous ventilation.

- Check whether the air inlet is installed in the manner that it cannot be blocked accidentally.

- If it is not possible to make direct supply of outside air through the wall located behind the stove (the wall is not external), an opening must be made in any of external walls of the room with the stove in place.

- If the room has no external walls, it is possible to make an external opening in the adjacent room and provide continuous supply of air through the gasket on the wall between the two rooms.

- If the stove is installed in the room with gaskets for air extraction or in the room with already existing appliances that extract the air from the room during operation, you should always pay attention that the amount of incoming air into the room is sufficient to ensure safe operation of the stove and already existing appliances.

- **It is forbidden to supply air for combustion purpose from the area with fire risk, for example garage, warehouse, depot and similar.**

If in the area where the stove is installed, one or more air extractor fans are in function, it is necessary to check whether the stove is operating poorly due to less air flow necessary for combustion.

- Flue duct for smoke extraction must be carried out in accordance with the applicable regulations both in terms of size and materials used for the construction.

- To avoid bi draught problems, each stove should have its own independent chimney.

- The use of conventional chimney is possible if the following rules are observed:

- Check whether the area for smoke extraction in the chimney is clear of obstacles
- In case of an older chimney, it is recommended to perform rehabilitation i.e. introduction of steel pipe of suitable diameter with adequate insulation (rock wool).
- Minimum cross section should not be less than 12x12 cm or minimum diameter \varnothing 120 mm
- Chimney height 4 – 5m as a minimum.

If the chimney is not cleaned regularly, the following problems may occur during the operation of stove:

- poor combustion,
- soiling of glass,
- deposition of ash and soot in the chamber, leading to poor heat transfer.

4. Installation of the Stove in the Area, Combustion Air Supply and Ventilation

4.1 Air Combustion Supply and Ventilation

Combustion air must be supplied to the rooms where the stove is installed. The room should be ventilated continuously. Fresh air inlet should be located at the bottom of room, with the air passing inside the inlet.

A) Combustion air supply via pipeline through the basement. For such option of connection, the combustion air is heated previously, which is useful regarding good and clean combustion. The installation of pipeline in the basement is simple.

B) Combustion air supply via basement. The combustion air is heated previously. The basement area should be separated from the ventilation system in the house and with external openings. Avoid high levels of dust and moisture.

C) Combustion air supply from above. Air supply from above can be done only with inspected chimney systems.

In this case it is necessary to calculate the exact size of chimney!

D) Combustion air supplied directly outside. If the air supply comes directly via external wall, the combustion air is only slightly preheated, which is unfavorable to clean combustion. In this case there is also a risk of condensation!

NOTE: These options of air supply are not recommended! However, if such options are implemented, contact qualified expert.

 The room with installed heating device must be supplied with sufficient fresh air. If windows and doors are sealed hermetically or the room with the installed stove is also equipped with devices such as hood, hair dryer, fan etc., which extract the air, the combustion air (fresh) must be supplied externally. In any case, the issue should be discussed with the competent chimney sweeper before the stove installation.

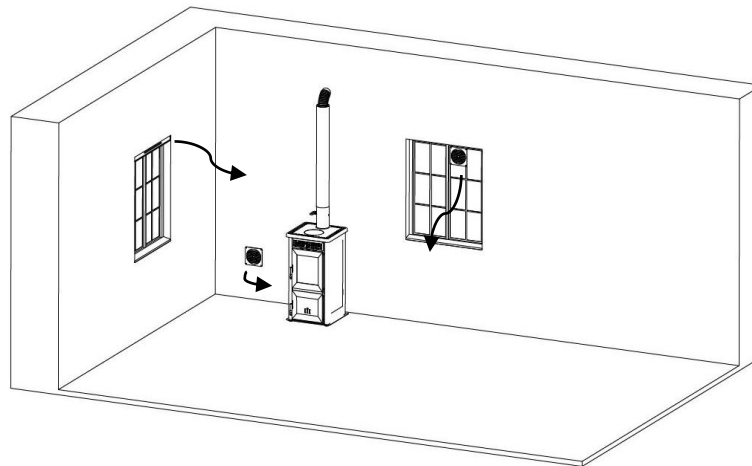

Figure 6 - Fresh air supply to the room with installed stove

Installation of all grates for the purpose of fresh air supply should be done so as not to cause blockage or closing off by accident.

4.2 Installation of the Stove

During stove installation you should follow valid regulations regarding the construction and firefighting requirements. The placement site should be horizontal and with sufficient bearing capacity, otherwise the appropriate measures must be applied for equal load distribution. In case of flammable floor (wood, plastics, textile...) it is necessary to put steel-sheet, copper or other inflammable material on the floor beneath the stove. Such base must cover the stove profile for at least 30 cm, and on the operation side it should be greater in length by 50 cm.

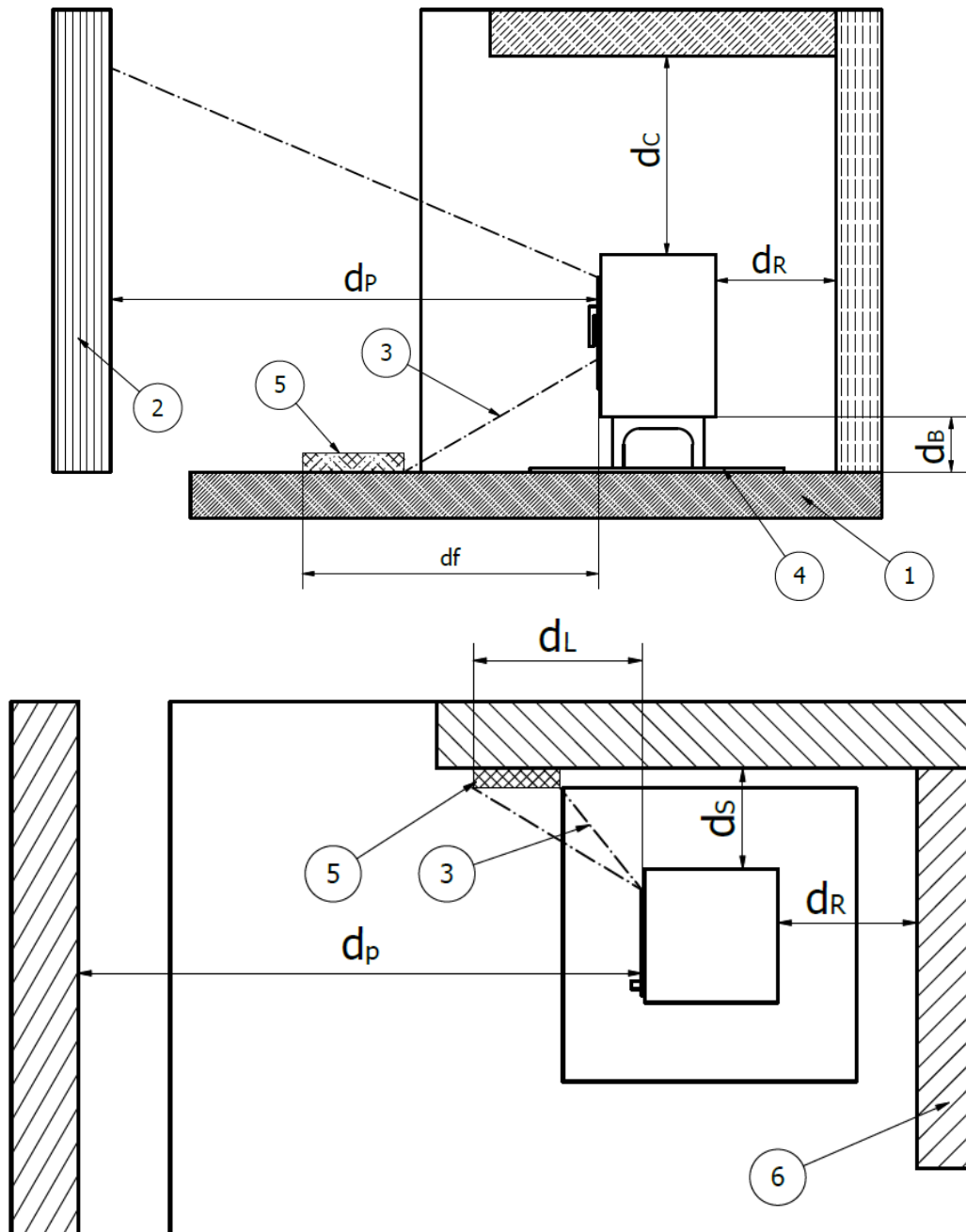

Figure 7 - All minimum safety clearances are listed on the technical nameplate, DO NOT use lower values than those specified (view CE MARKING INFORMATION).

Bottom (which is 0mm in case of appliances without feet)	d_B	0 mm
Floor in Front	d_F	1500 mm
ceiling	d_C	750 mm
rear	d_R	500 mm
side	d_S	500 mm
Side radiation area	d_L	1500 mm
front	d_P	800 mm

Table 4

1.	Trihedron floor
2.	Trihedron-like front plate
3.	Radiation area
4.	Floor protection plate
5.	Critical area (65K superseded due to radiation)
6.	Trihedron walls

Table 5

There should be enough space between the stove and flammable objects (with wooden sheeting, furniture, curtains etc.). The distance between the wooden parts of furniture or plastics and other flammable objects to be protected must be at least 80 cm to the sides and 50 cm on the back (Figure 7). There should be a distance of 90 cm at least between flammable objects from the stove filling opening.

Installation of objects above the stove is forbidden if the cast panel is used.

During the installation of used air drain pipe it is necessary to secure the distance of at least 50 cm away from flammable materials.

Before the stove is connected to the chimney it is mandatory to consult the local competent chimney sweeping organization. The flue-stove connection is done through the connecting elements according to SRPS.M.R4.031 (DIN 1298 or DIN EN 1856-2). Make sure that the chimney fittings do not protrude from the cross-section into the waste gas drain pipe, as well as that they have proper sealing function.

To achieve the best stove operation, the installation should be performed properly and perfect chimney should be provided. In any case it is necessary to inspect the existing flue pressure before the commissioning through the placement of lighted candle beneath the flue inlet. Chimney draught is considered sufficient if the flame bends towards the flue inlet. Slight flame bending indicates insufficient draught. The area where the appliance is installed should have satisfactory fresh air supply (Figure 6).

If two fireboxes are installed on a single chimney within a single floor (multiple engagement), the distance between the connections must not be less than 50 cm.

5. Stove Description

The stove is designed for periodically heating of closed spaces, with closed door. It is made of sheet-metal parts with grate, front frame, panel and door from cast iron. The firebox is lined with replaceable panels made of firesand. The external coating is enameled or painted. The air inlet necessary for ignition and combustion is located on the door to the ashpan. The back side holds the tertiary air inlets.

The fireplace is delivered with wood battens that fix fire sand panels and styropor that fix air deflectors. Before first use of the fireplace, it is necessary to remove wood battens and styropor. The wood battens should be removed carefully from the burner. The styropor should be removed by hand through the combustion chamber door, approximately at the same height as the decorative cover is placed.

Control of flue gas and vermiculite are packed in the burner and it should be unpacked and installed in accordance to the recommendations described in user manual. Vermiculite should be unpacked and installed in a way that it should be placed at the lateral holders of vermiculite, positioned completely forward, toward the glass.

Control of flue gas should be installed in a way that wider end of connector should be installed on the iron top plate, and narrow end of connector should be connected to flue pipes.

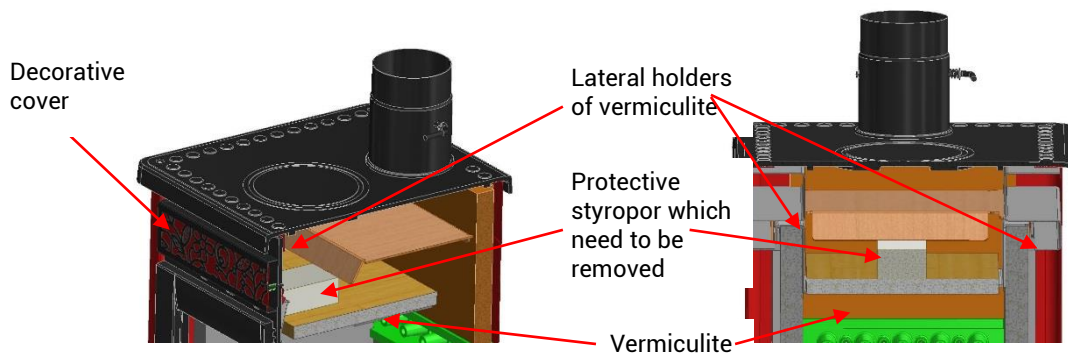

Figure 8. Styropor and vermiculite position

6. Air Control

Air control is performed on the combustion chamber door through an air control enabling the supply of primary air.

Make sure that the ashpan is not overfull. Discharge should be performed regularly to facilitate free air supply.

Secondary air intake is located on the stove door. Secondary and tertiary air provide oxygen necessary for clean combustion (complete burning of previously incomplete combustion products). Poor oxygen intake generates big emission of harmful substances, which could lead to chimney blockage.

6.1 Primary Air

Reliable fuel combustion is established on the basis of primary air. Such air is adjusted by the primary air control on the combustion chamber (figure 9, position 7). To ignite wood the control should be opened up to the maximum. Upon the ignition, the control should decrease to 3 mm.

NOTE: To prevent the stove overheating, fuel quantity must not exceed 2.25 kg of dry wood logs per hour, if the combustion air is properly adjusted.

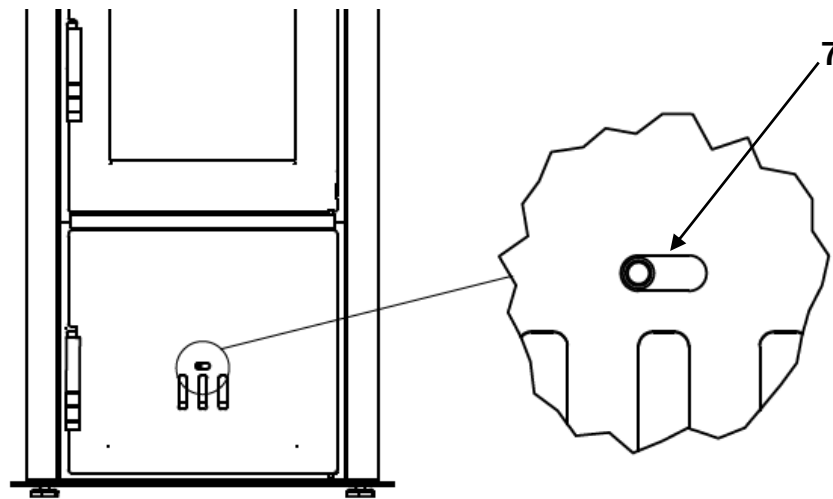

Figure 9

Model	Regulator	Putting out of working	Nominal heating performance	Starting
Amelia	one-hand air slide control			
		CLOSE	OPEN 3mm	3 minutes OPEN

Table 6

7. Stove Commissioning

Before the stove is stoked for the first time it is necessary to wipe the enameled surfaces with damp cloth to prevent the formation of stains. Painted surfaces should not be touched and no objects should be placed on the stove, so that the paint would not get damaged. Finally, the paint hardens only after several hours of heating.

After reading the operation manual, the stove is commissioned for the first time. During the first stoking you should open the windows because the anticorrosive protection produces unpleasant smell and smoke. That is normal phenomenon, but soon ends. If necessary, turn on the fan for faster air circulation. Stoke up to the maximum temperature load, 1 hour at least. If the maximum temperature is not reached during the first stoking, problems with unpleasant smell might occur later also.

Sensitive persons such as pregnant women and children should be outside the room during this phase. Some built-in parts (drain pipe, ashpan door, stove door) become hot during operation, posing a risk of burns. Handrail on the firebox door becomes very hot during the operation, therefore the opening and closing of the door could be done only with protective gloves (see figure 10).

Keep children away from the stove. When the stove is stoked for the first time, small quantities of fuel should be stoked three times to prevent the formation of cracks on the firesand.



Figure 10. Door handle

During the every ignition, in order to speed up the process, the control of flue gas damper should be open (picture 10a) by setting its handle in vertical position. After the ignition, the handle should be set in horizontal position, control of flue gas damper should be closed (picture 10b).

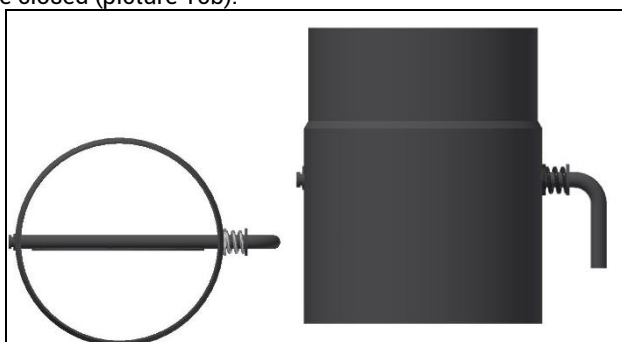

Figure 10a Opened control of flue gas damper

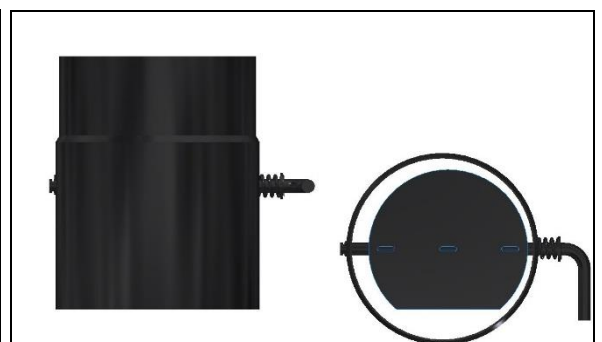

Figure 10b Closed control of flue gas damper

7.1 Stove Commissioning and Operation

- Open the primary air control damper to the maximum,
- Open the stove door,
- Insert soft wood shavings, chipboard or paper,
- Place two pieces of wood across,
- Ignite the paper,
- Close the stove door and slightly open the ashpan door,
- When the flame intensity increases, close the ashpan door and let the wood burn away .

Upon the formation of ember, feed new fuel and set the air control damper, so that it remains open 1/3. Never feed new fuel to flame!

ATTENTION

During the stove operation and wood logs are to be placed inside, the door should have two-phase opening mechanism: first, the door should be open slowly and partially (up to 3 cm), so smoke could be sucked into the chimney, and then the door could be fully open, but slowly to prevent ember fallout. At sudden opening, the stove door initiates the movement of certain amount of smoke. **If adding fuel, the door should be opened carefully to eliminate smoke. This method stops smoke from entering the room.**

Nominal heat output is achieved with the following fuel quantities and the primary air control damper settings.

Fuel type	Fuel quantity	Combustion time	Air control on the stove door near the ashpan
	kg	h	mm
wood logs	2.25	1	3 mm

Table. 7

The stove may be stoked only with natural wood logs. Wood logs are placed in pieces whose length measures 20cm. Remember, this stove is not an appliance used for waste incineration.

While the stove is in function, the door has to be closed. Slightly above the door there are openings used for cleaning glass, with their function to enable the air supply inside the stove.

Lacquered, painted, veneered and impregnated firewood or wood treated with glue should not be used for the stove. In this case any manufacturer's warranty and liability become void. Firewood should be used dry (humidity up to 20%). As a rule, wood becomes dry after being stored in dry and well-ventilated place for two years. Wet wood has low calorific value and forms sediments inside the flue pipes, as well as the chimney.

Under the most adverse weather conditions certain hindrances could occur in the chimney (eg. poor weather conditions). In such cases the stove operation is not allowed for safety reasons.

7.2 Maintenance and Cleaning

The stove should be inspected regularly by an expert. The stove, flue pipe and chimney should be cleaned regularly several times a year, at least once in the heating season.

Regular maintenance and cleaning are important for proper and reliable stove operation. Maintenance of enameled or painted surfaces is recommended only when the stove has cooled down. The stove should be cleaned with clean water and a soft cloth. Painted surfaces are cleaned with dusting brush or a dry cloth. Do not use water or damp cloths for cleaning painted stoves. The cleaning frequency depends on the type of fuel, namely the stove service life and the operation method.

The ashpan (figure 11) should be regularly emptied before each stove operation. The grate should be cleaned 1-2 times weekly. In case of clogged air inlet with slag or other combustion residues, these should be immediately eliminated and the grate should be cleaned thoroughly. When it comes to stoking, soot formation should be avoided. Soot is produced during the combustion for the following reasons:

- Poor draught in the chimney (poor-quality chimney)
- The stove is handled improperly, eg. oxygen supply is interrupted too early. We do not have any influence on the above mentioned facts. Therefore, we cannot assume any responsibility for clean glass.

Glass on the door should be cleaned only if the stove has cooled down, with a cloth or newspaper soaked and dipped into ashes; the contaminated parts should be wiped down until they are clean completely. Regular detergents can also be used. While the stove is in function, the glass should not be cleaned for safety reasons! Under normal conditions the glass becomes dark in the ignition phase; however, the color disappears during the use.

ATTENTION

The ceramic glass is resistant to high temperatures, but it could break due to thermal shock or heavy blow, therefore the glass should not be punched.

Cracks seen on the metal-sheet surface are created under normal thermal expansion during regular operation. These cracks do not compromise the work of the stove at all.



Figure 11

For optimal operation of the stove the following actions are necessary:

- Occasional and comprehensive cleaning,
- Occasional cleaning of the flue pipe to eliminate smoke and possible residue,
- Occasional cleaning of flue gas compartments (from firebox through the flue pipe),
- Empty the ashpan on the bottom of stove and remove all ash residue,
- Clean the chimney once a year to prevent sediment formation, otherwise in high temperatures such sediments could ignite, with severe consequences to the chimney and the entire house caused by improper behavior.

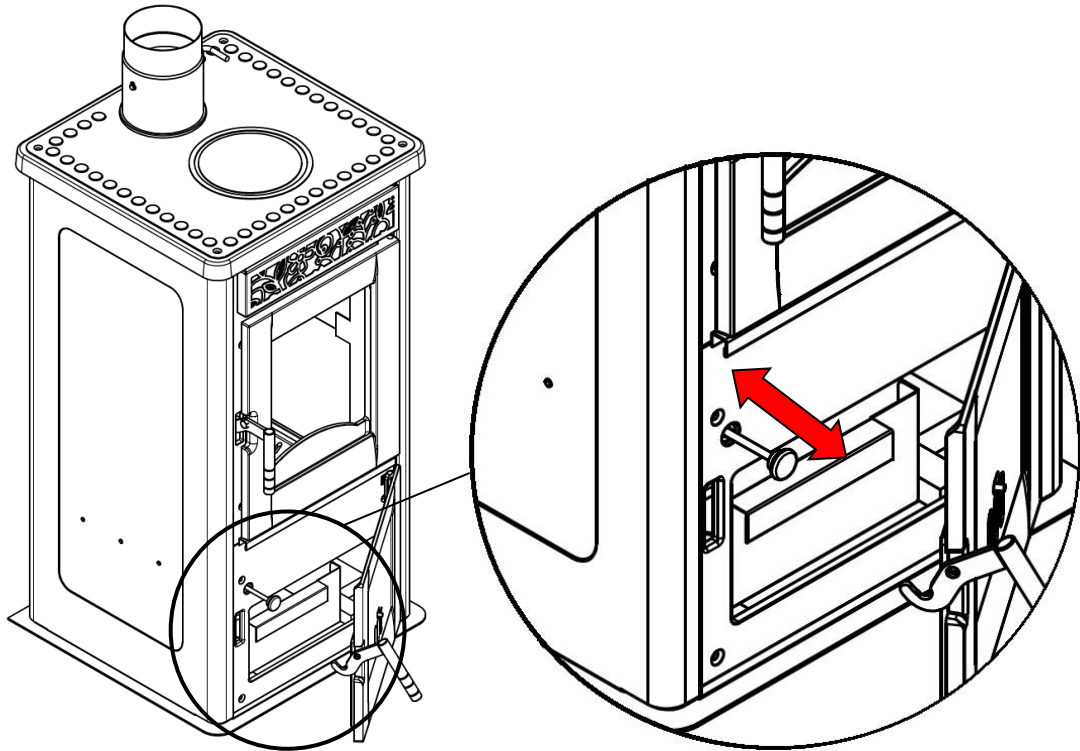



Figure 12

Shaking of the grate is performed via the knobs presented on figure 12.

8. Safe Operation of the Appliance

 Radiation from the stove, especially through glass surfaces, can ignite flammable objects surrounding the appliance. For that reason, you should adhere to the instructions regarding clearance as specified by chapter 3 Installation of the Stove.

 The external surfaces on the stove may be extremely hot during the operation, you should be careful and always use protective gloves.

That is why it is very important to pay attention to the following while the stove is in function:

- don't get close and touch glass on the firebox door and oven door, there is DANGER OF BURNS,
- don't get close and touch exhaust pipe, there is DANGER OF BURNS,
- don't perform any cleaning activities on stove while the stove is in function,
- don't empty ashes while the stove is in function,
- children and pets should be kept away from the stove,
- ADHERE TO ALL RECOMMENDATIONS CONTAINED IN THE MANUAL.

For proper use of the stove, you should do the following:

- use only fuel in compliance with the manufacturer's instructions,
- always adhere to the stove maintenance plan,
- clean the stove according to the recommendations within the manual
- don't use the stove in case of malfunction or other irregularities during operation, unusual sound and/or you suspect malfunction,

- **don't spray or spill water on the stove, even for putting out fire,**
- don't lean on the stove, as the stove may not be stable enough and COULD OVERTURN,
- don't touch painted parts of the stove while in function,
- use only recommended firewood specified in the user manual
- don't use the stove for burning waste,
- always perform all actions with maximum safety measures.

The manufacturer is always at your disposal to provide all necessary information regarding the stove, as well as installation instructions for your conditions. Proper installation of stove in compliance with the manual, as well as local and national regulations is very important to prevent danger, fire and any malfunction or poor operation.

In terms of complaints regarding errors or defects related to function you should contact our service center.

Use only original parts on the stove as recommended by the manufacturer.

The stove works with negative pressure in the combustion chamber. For that reason, you make sure that flue exhaust system is well sealed thermally.

DANGER: In case of fire in the exhaust pipe or chimney, evacuate all people and pets from the room and call firefighters immediately.

DANGER: The stove is not intended for the combustion of lignite or other types of fuel.

DANGER: Don't use the stove for burning waste.

 In case of fire or overheating, close the air inlet cover and do NOT open the door of the stove. Extinguish fire with the appropriate means (household fire extinguisher, ...). NEVER USE WATER TO EXTINGUISH FIRE! In case of fire you should also inform the local firefighters. Adhere to the local fire protection regulations!

 **Never** use gasoline, gasoline fuel for lanterns, kerosene, lighter fluid, ethyl alcohol or similar liquid to start or rekindle fire. Keep all liquids away from the appliance while in function.

The stove may not be used if the gaskets on the firebox door, ash dump door, cleanout opening are damaged.

Primary air control should be closed upon completion of combustion process.

WARNING: Fumes generated from blocked chimney are harmful. Keep the chimney and the flue pipe clean; clean according to the instructions. Exhaust pipes should be kept clean; clean according to the instructions.

Use only recommended fuel. Read the user manual.

 Firebox door and ash dump door should be closed at all times during the use of appliance (except for stoking, additional refueling and ash clean-up) in order to prevent the release of products of combustion (smoke).

9. Potential Malfunctions and Problems during Operation

Potential malfunctions and solutions for wood-burning stoves:

Malfunction	Solution
Combustion of wood with great speed	Check sealing tapes on the door Check door hinges and closing mechanism. Check the damper for control of flue gas. Is in the appropriate position and not damaged. Check that the chimney draught would not be too great. Check whether the appropriate fuel is combusted.
Stove makes whistling and other similar sounds	Stove whistling may be a sign that stabilizer or chimney cap is required. Whistling is a result of combustion air entering the stove through restricted pathway and over sharp or angular edges. It is usually caused by great draught above 20 Pa (Pascal). Whistling is also experienced more often for stoves with tertiary air inlet. If you experience whistling of stove, we recommend you to check chimney draught.
Stove makes clicking sound (crackling)	It is normal for wood-burning stove to produce certain sounds during stoking. Cause is the expansion and contraction of metal component when heated.
Too much smoke	Continuous emission of smoke could be harmful potentially and should not be tolerated. In case of continued emission of smoke: Open doors and windows to ventilate the room. Exit the room. Seek expert advice, if necessary. You may have a cold stove and cold chimney that might need small fire before lighting. Read more about cold chimneys. Burning wet wood logs may lead to the combustion with more smoke and odors. Read more about burning wet wood logs. Poor quality of chimney – Check chimney draught Adding fuel at the wrong time – Fuel should be added only when there is no flame, namely on a hot ember. When you are done using the stove and the fire is out, don't be tempted to turn off the air controls. Leave the levers fully open and allow air to enter the stove and pass through the chimney to prevent blockage of cold air. Air control malfunction. Check the furnace air control guide during ignition and refueling.
Corrosion on cast parts	In case of corrosion on cast parts, remove corrosion with abrasive material and then apply neutral vaseline to the treated surface.
Damaged sealing tapes	Sealing tapes guarantee the impermeability of product and subsequently good operation. They must be inspected periodically. In case of damage, they must be replaced immediately.

Table. 8

10. Disassembly, Recycling and Safe Disposal at the End of Service Life

Disassembly and disposal of old stove that shall no longer be used is complete responsibility of the stove owner.

The stove owner must comply with applicable legal regulations of relevant country with regard to safety and protection of environment.

Disassembly and disposal of the stove can be entrusted to the third party, provided that it is a company authorized for the collection and disposal of such materials.

ATTENTION

The product is delivered together with the guidelines for disposal of stove at the end of service life.

It is necessary to follow the instructions contained in the manual during the disassembly of the stove.

NOTIFICATION: In all cases, you must comply with applicable legal regulations of relevant country regarding the disposal of such materials (objects) and, if necessary, report the disposal of such objects.

ATTENTION

Disposal of stove at public place is a dangerous threat for people and animals. In such cases, the owner is always liable for injuries to people and animals.

Once the stove is disassembled, CE marking, the user manual and all other documentation related to the stove must be destroyed.

11. General data

If you adhere to the instructions for installing and use of the stove, this stove will be a reliable source of heat. All problems with Your stove can be resolved by our service. In case of complaints regarding problems or mistakes about the functions, please contact our service. They will help You as well as for orders of spare parts.

12. Information on Use and Transport

During the stove relocation make sure that the stove remains in balance, therefore avoid sudden movements.

Before any movement is done, check whether the forklift has the load capacity greater than the weight of the stove in question: the operator is in charge of lifting the load.

Pay attention that the children do not play with the packaging components for safety reasons.

13. Frequently Asked Questions

The ignition problems:

- Open the primary air and if necessary, open the ashpan door slightly,
- Use well-dried wood logs,
- Check whether the flue pipes are well-connected,
- Check the draught in the chimney,
- Check whether the ashes and the combustion residue have clogged the exhaust pipes or the firebox grate.

Glass gets dirty very quickly:

- Wet wood logs: use dry firewood (10-20% relative humidity),
- Check whether the ashes and the combustion residue have clogged the exhaust pipes or the grate,
- Inappropriate firewood,
- The stove does not have sufficient pull (see the connection and the chimney),
- Setting is not well-adjusted: if the secondary air inlet is closed, the glass gets dirty quickly,
There is a condensate inside the combustion chamber.
- In the first few ignitions the formation of condensate is expected, as the materials covering the stove contain moist,
- Check whether the chimney size is too big and whether the flame reaches the chimney top.

14. The Nameplate

The nameplate is attached to the back or the bottom of stove, containing serial number that should be listed for each order.